

# Chapter 4

## Bridge Program Drawings

### Section 4.09-Superstructure

#### Introduction

The superstructure is the part of the bridge that stabilizes and supports the slab and transfers the traffic load to the bridge substructures. There are numerous types of superstructures; however, the most commonly used are steel girders (rolled beam or welded plate) and prestressed-precast concrete girders.

#### Superstructure Types

**ROLLED BEAM GIRDERS** (W Girders) are manufactured steel sections typically used for short span(s) and/or tight vertical clearance situations. An example is W 27 x 94, where W is the designation for wide flange, 27 is the approximate girder depth in inches, and 94 is the weight of the section per linear foot in pounds. The usual depth of rolled beam girders ranges from 24" (W 24) to 40" (W 40). This superstructure type is typically the easiest to design and detail. Detail rolled beams using nominal dimensions listed in the AISC Steel Construction Manual.

**WELDED PLATE GIRDERS** are fabricated steel sections comprised of web and flange plates welded into an I configuration. Welded plate girders are typically used for longer spans.

**PRESTRESSED-PRECAST CONCRETE SECTIONS** are fabricated girders of various sizes and shapes. Examples of those most commonly used are I-Girders, Bulb T's, Twin T's, and Tri-decks, although other sections are available and may be used.

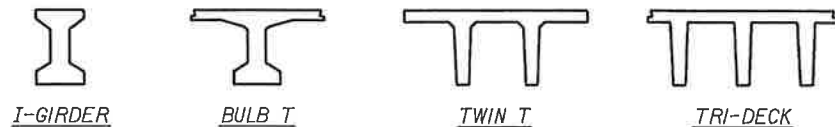

#### General Design and Detail Information Steel Girders

**STRUCTURAL STEEL** used in the fabrication of superstructures shall be ASTM A709 Grade 50, 50W or HPS 70W. ASTM A992 may be used for non-weathering steel rolled sections. Currently, hybrid girder construction shall be avoided due to small differences in material costs, except when using high performance steel. To ensure proper fabrication of structural steel components, AISC Certification will be required as follows:

<b>AISC Certification Categories for Bridge Fabrication</b>			
<b>Fabricated Item</b>	<b>AISC Certification Category</b>		
	<b>Simple Bridges</b>	<b>Intermediate Bridges</b>	<b>Advanced Bridges</b>
Un-spliced rolled section	•		
Straight rolled section with field or shop splices		•	
Curved rolled section with field or shop splices w/a radius over 500 ft		•	
Straight built-up I-shaped plate girder section w/ constant web depth ( <u>except</u> for dapped ends)		•	
Curved built-up I-shaped plate girder section w/ constant web depth ( <u>except</u> for dapped ends), with or without splices, w/ radius over 500 ft		•	
Curved built-up I-shaped plate girder section w/ constant web depth ( <u>except</u> for dapped ends), with or without splices, w/ radius less than 500 ft			•
Straight built-up I-shaped plate girder section w/ variable web depth (haunched)		•	
Curved built-up I-shaped plate girder section w/ variable web depth (haunched) and radius over 1000 ft		•	
Curved built-up I-shaped plate girder section w/ variable web depth (haunched) and radius less than 1000 ft			•
Curved or straight built-up I-shaped plate girder section w/ constant web depth and dapped ends			•

The following table can be used as a starting point to determine the number of girders and girder spacing to be used with curbs. If a sidewalk is used or if other conditions exist, the number of girders and spacing will require modification; however, for rolled beam girders, the cantilever shall not exceed 3'-0".

**Bridge Railing Type : TL3&4 – NCHRP350    Curb Width : 1'-8"**

<b>Table of Girder Spacing</b>							
Clear Roadway Width	Out-Out Width	Number of Girders		Girder Spacing (C-C)		Cantilever	
		Wide Flange	Welded Plate	Wide Flange	Welded Plate	Wide Flange	Welded Plate
16'-0"	19'-4"	3	3	7'-0"	7'-0"	2'-8"	2'-8"
20'-0"	23'-4"	3	3	9'-0"	8'-0"	2'-8"	3'-8"
22'-0"	25'-4"	4	3	7'-0"	9'-0"	2'-2"	3'-8"
26'-0"	29'-4"	4	4	8'-0"	7'-6"	2'-8"	3'-5"
28'-0"	31'-4"	4	4	8'-6"	8'-0"	2'-11"	3'-8"
30'-0"	33'-4"	4	4	9'-3"	8'-6"	2'-9½"	3'-11"
32'-0"	35'-4"	5	4	7'-6"	9'-6"	2'-8"	3'-5"
34'-0"	37'-4"	5	5	8'-0"	7'-6"	2'-8"	3'-8"
36'-0"	39'-4"	5	5	8'-6"	8'-0"	2'-8"	3'-8"
38'-0"	41'-4"	5	5	9'-0"	8'-6"	2'-8"	3'-8"
40'-0"	43'-4"	5	5	9'-6"	9'-0"	2'-8"	3'-8"
42'-0"	45'-4"	6	5	8'-0"	9'-6"	2'-8"	3'-8"

<b>Bridge Railing Type : TL4 - MASH Curb Width : 1'-3 ½" *</b>							
<b>Table of Girder Spacing</b>							
Clear Roadway Width	Out-Out Width	Number of Girders		Girder Spacing (C-C)		Cantilever	
		Wide Flange	Welded Plate	Wide Flange	Welded Plate	Wide Flange	Welded Plate
26'-0"	28'-7"	4	4	8'-0"	7'-6"	2'-3 ½"	3'-0 ½"
28'-0"	30'-7"	4	4	8'-6"	8'-0"	2'-6 ½"	3'-3 ½"
30'-0"	32'-7"	4	4	9'-3"	8'-6"	2'-5"	3'-6 ½"
32'-0"	34'-7"	5	4	7'-6"	9'-6"	2'-3 ½"	3'-0 ½"
34'-0"	36'-7"	5	5	8'-0"	7'-6"	2'-3 ½"	3'-3 ½"
36'-0"	38'-7"	5	5	8'-6"	8'-0"	2'-3 ½"	3'-3 ½"
38'-0"	40'-7"	5	5	9'-0"	8'-6"	2'-3 ½"	3'-3 ½"
40'-0"	42'-7"	5	5	9'-6"	9'-0"	2'-3 ½"	3'-3 ½"
42'-0"	44'-7"	6	5	8'-0"	9'-6"	2'-3 ½"	3'-3 ½"

\*Note: Curb width includes 1 ½" slab extension beyond RF of the curb.

When a very shallow girder depth is required, consideration should be given to minimizing the cantilever length. If possible try to

limit the cantilever length to the girder depth.

Minimum plate sizes for welded plate girders shall be as follows:

$\frac{5}{16}$  " plate thickness for all material

$\frac{5}{16}$  " girder web thickness (in  $\frac{1}{16}$  " increments and 1" web depth increments)

$\frac{3}{4}$ " x 12" flange (in  $\frac{1}{8}$  " thickness increments up to 1 $\frac{1}{2}$ " with  $\frac{1}{4}$ " increments thereafter and 1" width increments)

Minimum web thickness for rolled beam girders shall be  $\frac{1}{4}$ ".

All superstructure sheets shall be detailed showing true girder lengths including grade and vertical and horizontal curvature. Rolled beam girders shall always be detailed based on the actual vertical curve information.

The **FRAMING PLAN** is a stick diagram defining the location and orientation of stiffeners, bottom lateral bracing, cross frames, diaphragms, splices, and substructures in relationship to the girders.

The **GIRDER ELEVATION** typically shows an interior girder configuration. When possible, the girder elevation should be directly below the framing plan and projected from either an interior or exterior girder line. The Framing Plan and Girder Elevation shall preferably be detailed full length, although a half plan may be used on long symmetrical structures.

**HAUNCHED GIRDERS** are welded plate girders with a deeper web plate over the piers to accommodate the larger negative moment of longer span bridges. These girders require an additional detail showing the limits and dimensions of the parabola, the arc, and a flat bearing section. When the web depth exceeds 12'-0", a longitudinal shop splice shall be required. If bottom lateral bracing is used in the haunched area, details shall be included showing the slope of each gusset plate.

Welded plate girders shall be cambered to compensate for dead load deflection, grade, or vertical curvature. The camber is shown in the **WEB CUTTING DIAGRAM** along with true camber ordinate spacing and horizontal lengths used to lay out blocking ordinates. A sufficient number of camber ordinates, usually at the tenth points of each span, shall be shown so that a smooth curve is formed. The number and size of these spaces and their relationship

to the ends of each piece shall be shown. If the blocking ordinates differ by more than  $\frac{3}{16}$ " between girders the ordinates shall be tabled.

In most cases camber is not required for rolled beam girders. Heat cambering for rolled beam girders should be avoided due to fabrication cost. If no camber is required for rolled beams, this should be noted in the plans.

A **BLOCKING DIAGRAM** shall be detailed for rolled beam girders when the slab thickness is less than the design slab thickness or thicker than the design slab thickness by 1" or more. This diagram shows blocking ordinates and true and horizontal girder lengths. If the blocking ordinates differ by more than  $\frac{3}{16}$ " between girders, the ordinates shall be tabled.

**GIRDER PIECE LENGTHS** should be kept to around 75'-0" for rolled beam girders W 27 and larger and 65'-0" for rolled beam girders smaller than W 27. Welded plate girder piece lengths should be kept to around 85'-0" and not over 120'-0".

**FIELD SPLICES** shall be used to control the piece lengths. Field splices are commonly located near the point of dead load contraflexure. Standard bolt patterns to be used in the web field splices shall be 3" x 3" for rolled beam girders and 4" x 4" for most welded plate girders, except when another pattern is required by design. The horizontal bolt spacing for flange splices is 3". The optional shop splice for welded plate girders shall be used on all girder piece lengths exceeding 60'-0". Care shall be taken to avoid placing the optional shop splice in high-stress areas. The optional shop splice for rolled beam girders shall be used and located at the discretion of the design engineer.

On skewed structures, the top and bottom flange may require a bevel cut to ensure that the girders clear the rear face of the abutment for embedded girders or the abutment backwall for non-embedded girders. The minimum distance from rear face abutment to the girder flange is 6".

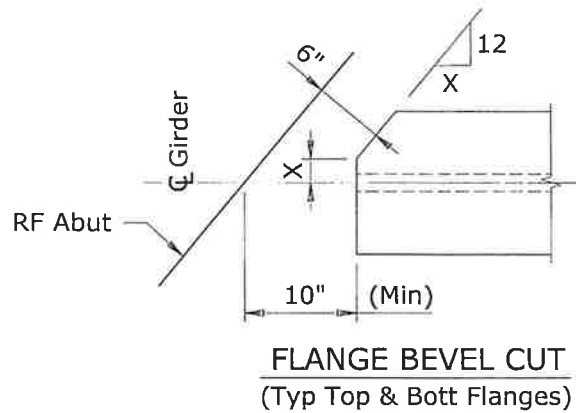

**SHEAR CONNECTIONS (STUDS)** are a mechanical means used at the junction of the girder and slab for developing the shear resistance necessary to produce composite action. Shear connectors are typically provided for the full length of composite girders. Shear stud diameters are typically  $\frac{3}{4}$ " or  $\frac{7}{8}$ " and will be specified in the design.

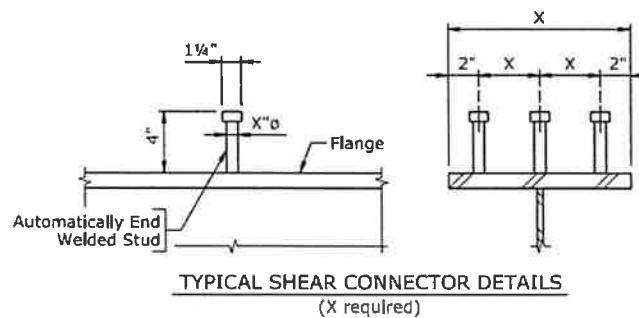

**TRANSVERSE STIFFENERS** are required to stiffen the web and provide a point of attachment for cross frames, diaphragms, and bottom lateral bracing. Stiffeners shall be placed normal to flanges except on bridge structures with extreme grades where it may be desirable to have the stiffeners placed vertically. The width of transverse stiffeners shall be in  $\frac{1}{2}$ " increments with a minimum width of 4". On beveled stiffeners, the largest width shall be called out in the Stiffener Details. Design required stiffener widths shall be specified in the design. The minimum stiffener thickness for welded plate girders shall be  $\frac{1}{2}$ " or the web thickness, whichever is larger. The minimum stiffener thickness

for rolled beam girders shall be  $\frac{5}{16}$ " at intermediate locations and  $\frac{1}{2}$ " at abutments and bents/piers. Stiffeners and stiffener welds shall be detailed.

The following type of stiffeners shall be used at cap-type abutments for rolled beam girders.

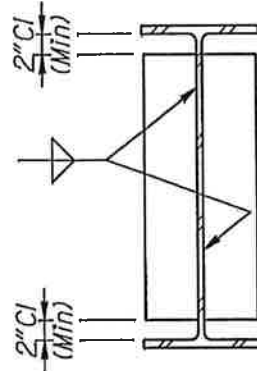

*(Interior and Exterior)*

The following types of stiffeners shall be used at the abutments for welded plate girders.

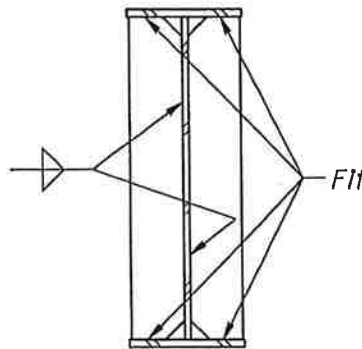

*(Embedded - Interior & Exterior)*

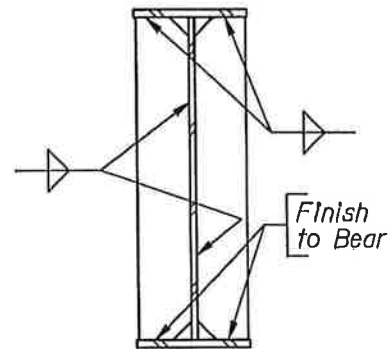

*(Non-Embedded - Interior & Exterior)*

The following type of stiffeners shall be used at the bents/piers of rolled beam girders when no stiffeners are required by design.

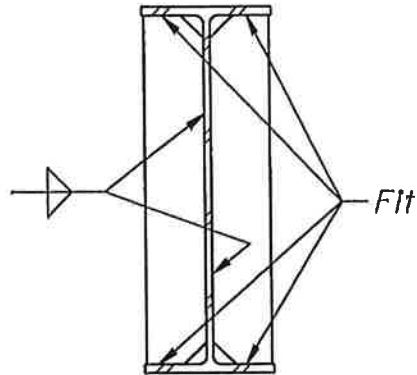

(Interior & Exterior)

The following type of stiffeners shall be used at the bents/piers of welded plate girders and at the bents/piers of rolled beam girders when stiffeners are required by design.

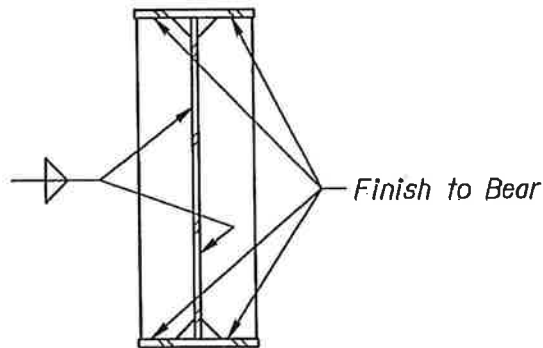

(Interior & Exterior)

The following type of stiffeners shall be used at intermediate locations of rolled beam girders.

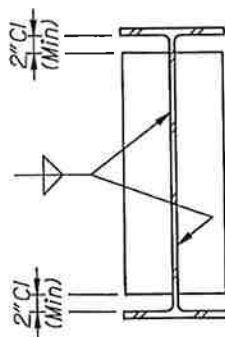

(Interior)

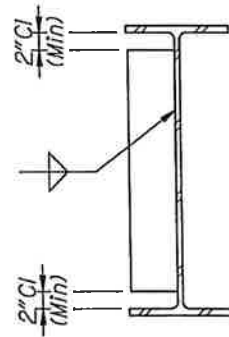

(Exterior)



The following types of stiffeners shall be used at intermediate locations of welded plate girders.

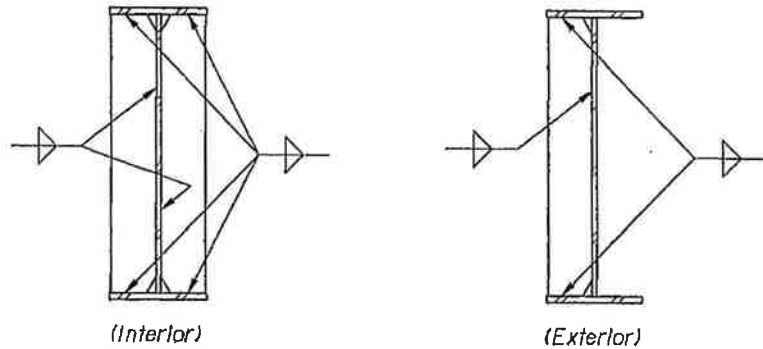

**STIFFENER CUTS** are required on welded plate girders so as not to interfere with the weld and on rolled beam girders so as not to interfere with the fillet. For skewed bridges, check standard stiffener cuts and enlarge as required to ensure adequate clearance from the web-to-flange weld or fillet.

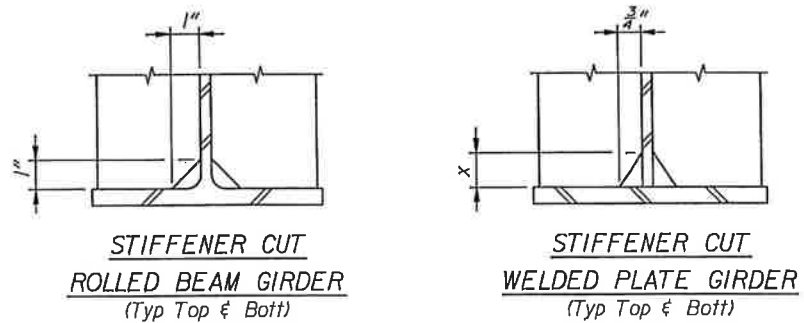

Recommended Stiffener Cut	
Web Thickness	Stiffener Cut (x)
5/16"	1 1/2"
3/8"	1 3/4"
7/16"	2"
1/2"	2 1/4"
9/16"	2 1/2"
5/8"	2 3/4"

Stiffener welds and bevel cuts shall be as follows.

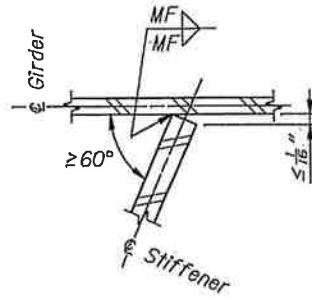

CASE I  
(Stiffener not beveled)

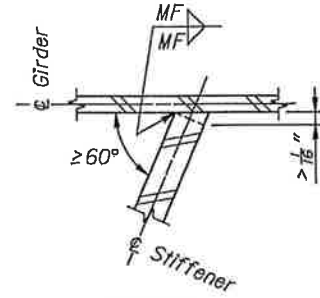

CASE II  
(Bevel Stiffener)

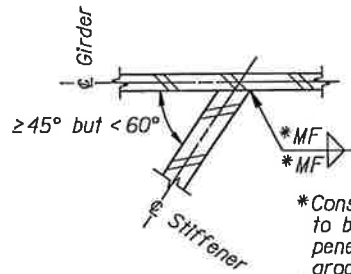

CASE III  
(Bevel Stiffener)

\* Considered to be partial penetration groove weld by AWS.

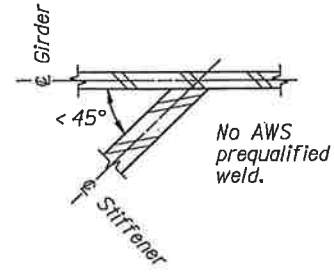

CASE IV  
(Bevel Stiffener)

PREQUALIFIED STIFFENER WELDS  
(MF = AWS Minimum Fillet Weld)

**LONGITUDINAL STIFFENERS** are used to prevent web buckling on certain welded plate girders. Longitudinal stiffeners should be avoided on most girders. They shall be placed one-fifth ( $1/5$ ) of the web depth from the inner surface of the compression flange. The minimum longitudinal stiffener thickness for welded plate girders shall be  $1/2$ " or the web thickness, whichever is larger. Details are required at optional shop splice and terminations such as cross frames, field splices, and bents. Details at both interior and exterior girders may be required.

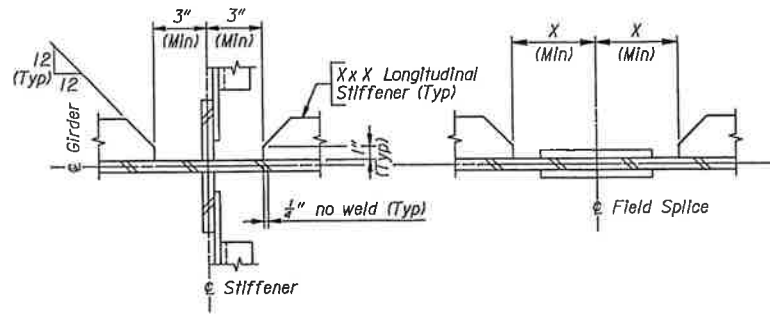

SECTION THRU INTERMEDIATE  
OR BEARING STIFFENERS

SECTION THRU FIELD SPLICE

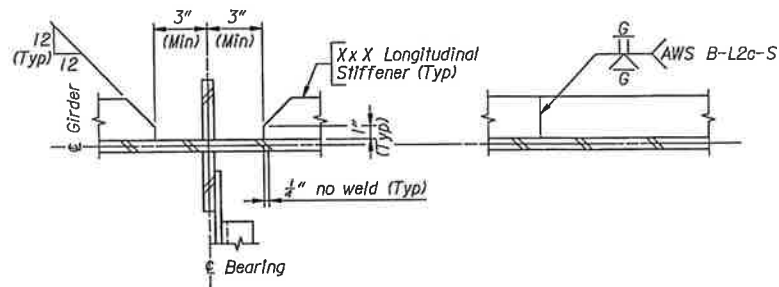

SECTION THRU BEARING STIFFENERS  
AT EXTERIOR GIRDERS

SECTION THRU OPTIONAL  
SHOP SPLICE

**CROSS FRAMES** and **DIAPHRAGMS** are secondary elements used to assist in erection and construction as well as to distribute loads laterally. Spans shall be provided with cross frames or diaphragms at each non-embedded end and at intermediate locations with spacing not to exceed 25'-0" for welded plate girders and 15'-0" for rolled beam girders. Cross frames and diaphragms are to be placed normal to girders unless the bridge skew is 20 degrees or less, in which case they shall be placed parallel with the substructure. Cross frames and diaphragms shall be in a continuous line across the girders when possible. Bent plates shall be used for diaphragms with the legs being 3½" to 4" and the thickness 3/8" maximum. The design engineer shall ensure that the cross frames and diaphragms do not interfere with the installation and operation of the anchor bolts at bent/pier locations. Cross frames and diaphragms shall be detailed as they are situated, normal or skewed, and show all information necessary for fabrication. Use of angles with equal legs is preferred for cross frames on weathering steel bridges due to availability.

The following are preferred types of cross frames and diaphragms to be used.

The **X TYPE** cross frame is the most common and preferred intermediate type, generally composed of angles and gusset plates bolted into place.

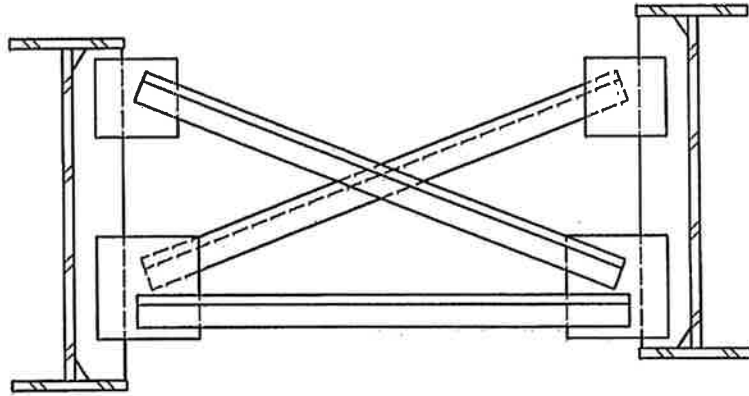

This version of the X Type cross frame is the most common and preferred type to use at bearing locations. The top horizontal member is usually a wide flange shape at slab supports or an angle when the top horizontal member is not loaded vertically.

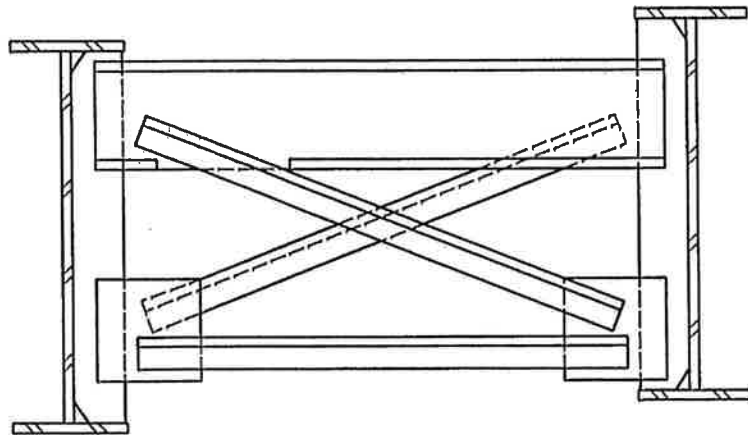

The **K TYPE** cross frame may be used when the angle between the diagonal and horizontal members in the X Type cross frame is less than 25 degrees.

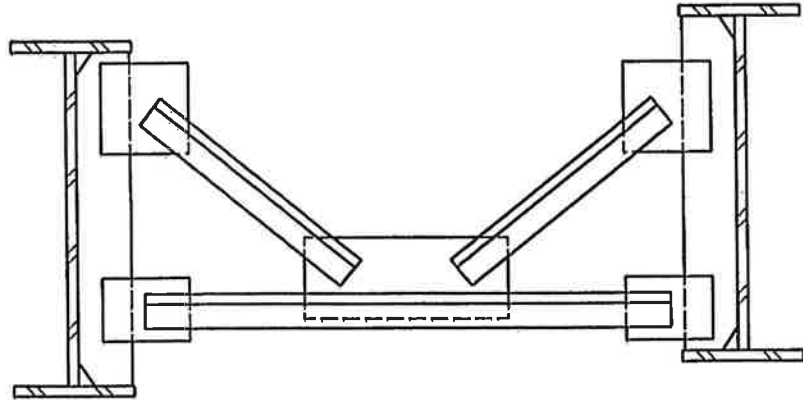

This version of the K Type cross frame is used at bearing locations when the angle between the diagonal and horizontal members in the X Type cross frame is less than 25 degrees. The top horizontal member is usually a wide flange shape at slab supports or an angle when the top member is not loaded vertically.

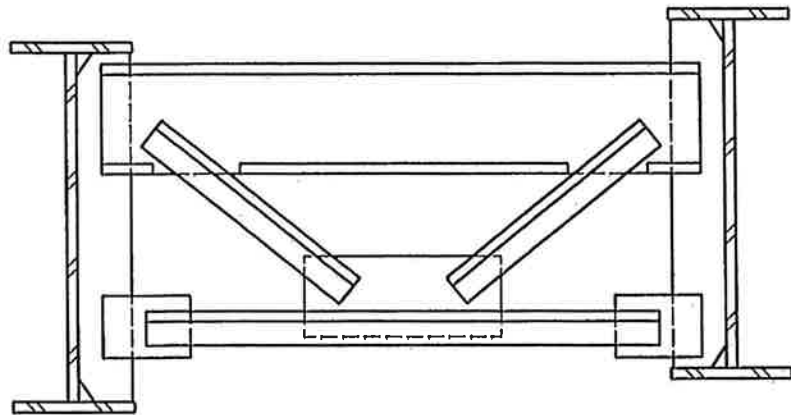

**DIAPHRAGMS** are used with shallow girders with web depths less than 40". Diaphragms shall be bent plates or channels.

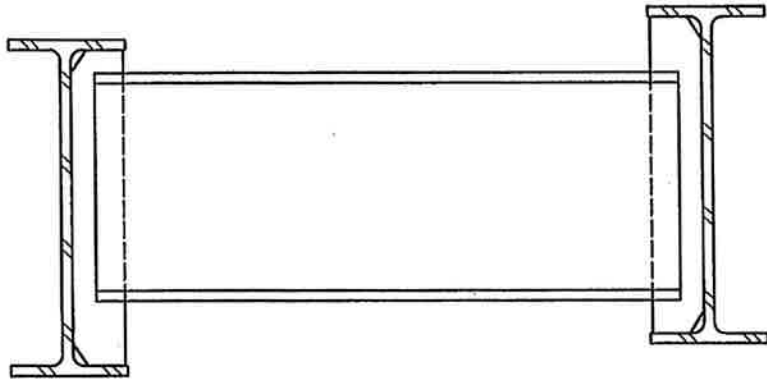

In detailing the geometry of K and X Type cross frames, the working line of the angle members will be placed at the center of the leg-

As a general guideline, the following sketches shall be used for clearances and dimensions.

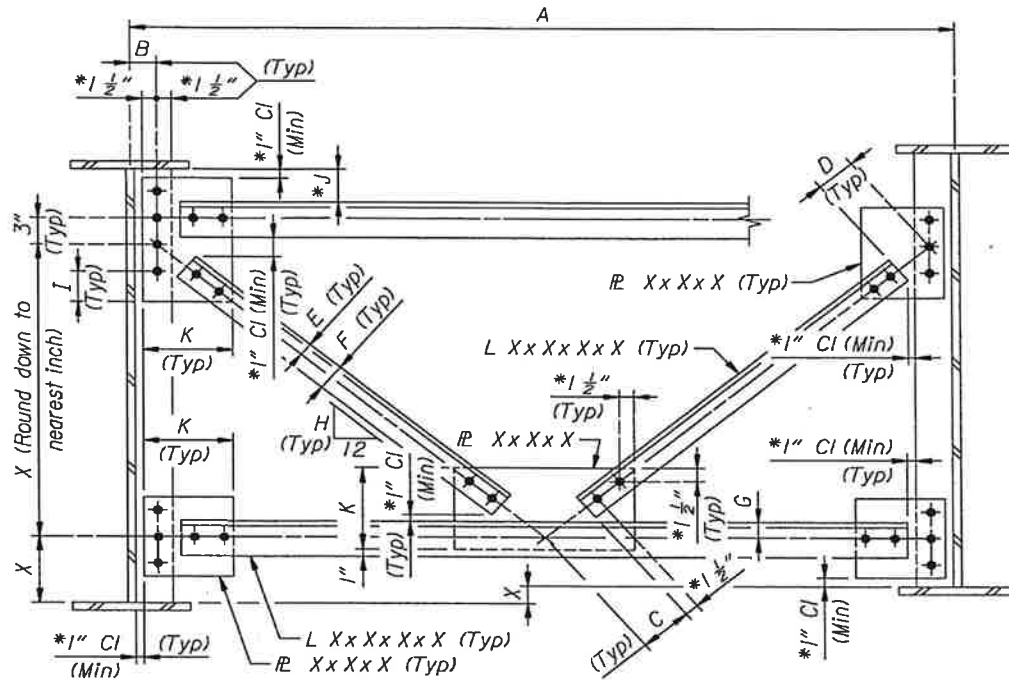

- A - Show skewed dimension if cross frame is skewed.
- B - Show dimension if stiffener is normal to web. If stiffener is skewed, show DETAIL A.
- C - Round up to nearest  $\frac{1}{2}$ ".
- D - Round up to nearest  $\frac{1}{2}$ ".
- E - Half of the angle leg.
- F - Call out if angle is made up of unequal legs.
- G - Half of the angle leg.
- H - Round to nearest  $\frac{1}{16}$ ".
- I - Round to nearest  $\frac{1}{16}$ ".
- J - 3" (Min), if possible, to facilitate use of stay-in-place forms
- K - Either the horizontal or vertical plate dimension can be shown.
- Gusset R's - Round up to nearest  $\frac{1}{16}$ ".
- Angles - Round to nearest  $\frac{1}{16}$ ".
- a, b, c & d - Round to nearest  $\frac{1}{16}$ ".
- \* - These dimensions are for figuring purposes and are not to be detailed.

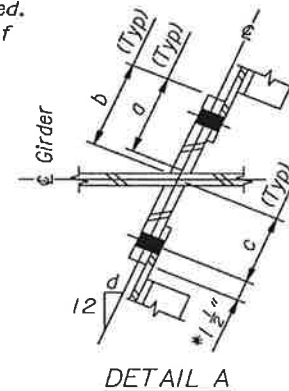

Add Note: Bolt pitch is 3" unless noted. The distance from center of bolt holes to edges is 1 1/2" unless noted.

CROSS FRAME  
(K Frame shown, X Frame similar)

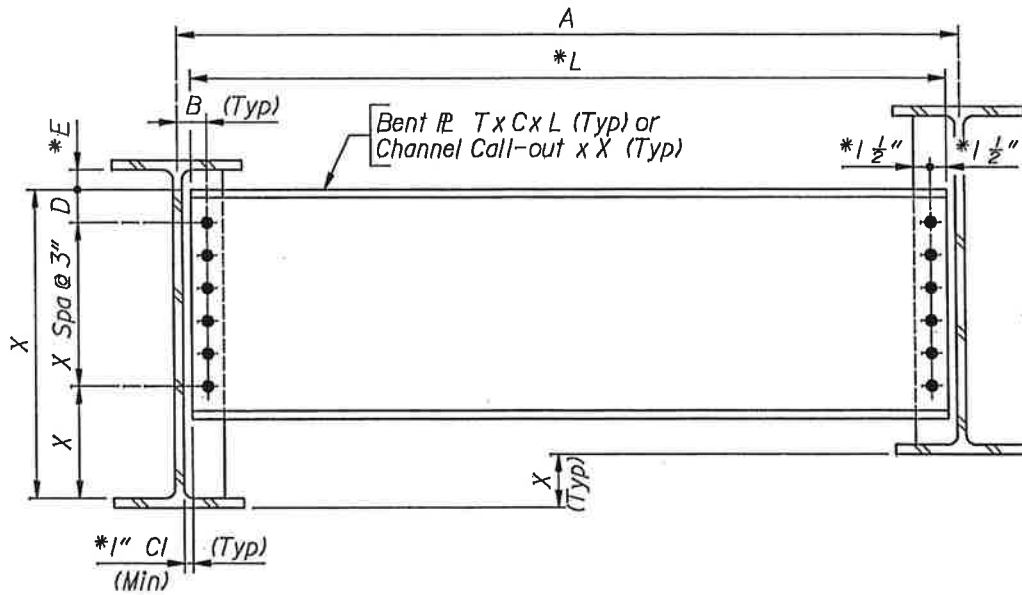

- A - Show skewed dimension if crossframe is skewed.
- B - Show dimension if stiffener is normal to web. If stiffener is skewed, show DETAIL B.
- C - Inside dimension of bent plate. Round to nearest  $\frac{1}{8}$ ".
- D -  $3" + T$  (Min), Round to nearest  $\frac{1}{16}$ ".
- E - 3" (Min), if possible, to facilitate use of stay-in-place forms.
- L - Length of bent plate.
- T - Thickness of bent plate.

a, b, c, d,

e & f - Round to nearest  $\frac{1}{16}$ ".

\* - These dimensions are for figuring purposes and are not to be detailed.

Add Note: The distance from the center of the bolt holes to edges shall be  $1\frac{1}{2}$ " unless noted.

DIAPHRAGM

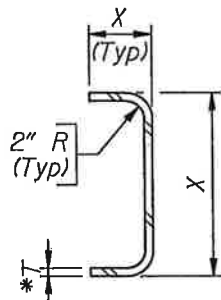

SECTION THRU DIAPHRAGM

(Show Section only if Bent Pl. is used)

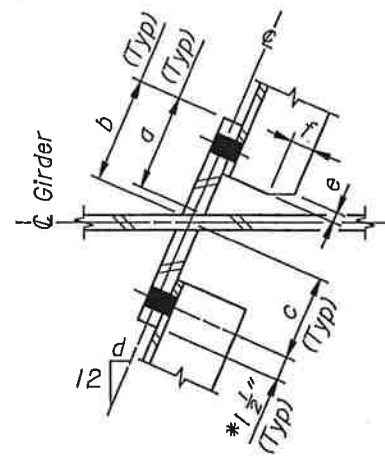

DETAIL B





**BOTTOM LATERAL BRACING** is primarily used to resist lateral forces due to wind. Bottom lateral bracing should be considered for spans greater than or equal to 125'-0". Bracing may be waived with the approval of the Bridge Program Staff. This may result in tighter cross frame spacing. All bracing shall be placed in the exterior bays between the cross frames as close to the bottom flange as possible. Bottom lateral bracing shall be shown on the Framing Plan and additional details are required as shown below.

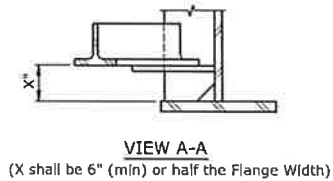
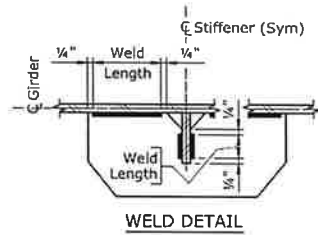
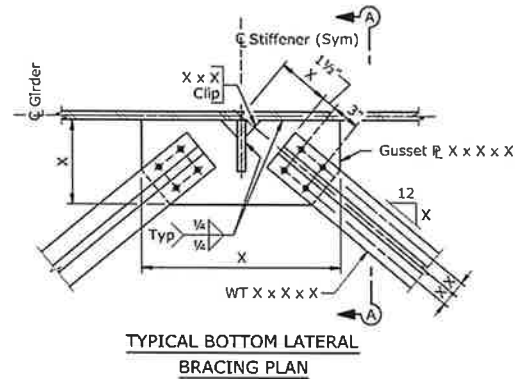

**FILLET WELDS** are used for the majority of welds. Unless a larger size is specified in the design, the weld size is determined by the thicker of the two parts being joined, except that the weld size need not exceed the thickness of the thinner part being joined. Minimum size fillet welds shall be made with a single pass. Fillet welds shall be held back 1/4" from the ends of the stiffeners and members.

<b>Minimum Size of Fillet Welds</b>	
Base Metal Thickness of Thicker Part Joined (T)	Minimum Size of Fillet Weld
$T \leq \frac{3}{4}"$	$\frac{1}{4}"$
$T > \frac{3}{4}"$	$\frac{5}{16}"$

**HIGH STRENGTH BOLTS** shall be 7/8" in diameter. If non-standard bolt size, bolt pitch, edge distance, and/or hole size are

used, they shall be shown in the design.

The table below shall be used for the minimum number of bolts required for connection of various cross frame, diaphragm, and bottom lateral bracing members, unless otherwise required by the design. Welding of cross frame members to gusset plates can lead to large member sizes and gusset plates due to poor fatigue category. It is more economical to use bolted members. Therefore, cross frame members will be attached to gusset plates with bolts.

<b>Table of Connections</b>	
□Member	Number of 7/8" $\phi$ HS Bolts
WT 4 x 8.5	4
WT 4 x 10	4
WT 4 x 12	4
WT 5 x 10.5	4
WT 5 x 12.5	5
L 3 x 2½ x 5/16	2
L 3 x 3 x 5/16	2
L 3½ x 3 x 5/16	2
L 3½ x 3½ x 5/16	2
L 4 x 3½ x 5/16	2
L 4 x 4 x 5/16	2
L 5 x 5 x 5/16	3
L 6 x 4 x 5/16	3
L 6 x 6 x 3/8	5

□ Use of angles with equal legs is preferred for weathering steel bridges due to availability.

3" bolt spacing shall be used for channels and bent plate diaphragms. The number of bolts should be maximized to fit within the section and based on the dimensions shown in the Bridge Applications Manual.

**BEARINGS** are provided at each intersection with the substructure. The most common types of bearing used are Elastomeric Bearing Devices and ½" Elastomeric Bearing Pads. Elastomeric bearing devices transfer the load from the superstructure to the substructure and allow thermal expansion and

contraction of the superstructure. These shall be designed in accordance with the latest AASHTO specifications. Elastomeric bearing pads are used when the superstructure is integral with the substructure to allow for initial girder rotation and provide a smooth bearing surface for the girder. Skewed bridges require ½" bearing pads to be clipped flush with the front face of the substructure.

**BEVEL PLATES** shall be detailed when specified in the design. Bevel plates shall be placed between the pad and the girder flange. The minimum thickness of the bevel plate shall be ¾" and increase in size in ⅛" increments at the thickest part of the plate. Plate thicknesses shall be detailed to 1/16" at the beveled end.

**ANCHOR BOLTS** shall be used to securely anchor the girders to the substructure. Anchor bolts shall be threaded or swedged, which allows the material in which they are embedded to securely grip them. Anchor bolt lengths shall be in 1" increments. The following are the minimum requirements for each bearing.

<b>Table of Anchor Bolts</b>			
Span Length	Number of Bolts	Bolt Size (Diameter)	Distance Set into Masonry
50'-0" or less	2	1"	10"
51'-0" to 100'-0"	2	1¼"	12"
101'-0" to 150'-0"	2	1½"	15"
150'-0" or more	4	1½"	15"

Note: Use longest span immediately adjacent to bearing.

Anchor bolt holes shall be formed holes or round drilled holes as shown in the following table. The minimum clear distance from a drilled hole to the face of any reinforcing steel shall be 1".

<b>Table of Anchor Bolts</b>		
Anchor Bolt (Diameter)	Formed Hole	Drilled Hole (Diameter)
1"	1¾"	1½"
1¼"	2"	1¾"
1½"	2¼"	2"

**COEFFICIENT OF THERMAL EXPANSION** is a value for a given material representing the change in length for each degree of temperature change. The coefficient of thermal expansion for use on steel superstructures shall be  $6.5 \times 10^{-6}$  per degree Fahrenheit. The temperature ranges for steel superstructures are shown below. The movements will be determined from a base temperature of 60

degrees Fahrenheit.

For LRFD: Temperature Range =  $-50^{\circ}\text{F}$  to  $130^{\circ}\text{F}$

For LFD or ASD: Temperature Range =  $-40^{\circ}\text{F}$  to  $120^{\circ}\text{F}$

**EXPANSION DEVICES** allow for the movement of the superstructure caused by temperature changes. For longer spans the **FINGER TYPE DEVICE** or the **MODULAR EXPANSION JOINT** shall be used. Other situations require the **EXPANSION JOINT (GLAND)**, the **ELASTOMERIC COMPRESSION JOINT SEAL**, or the **COMPRESSED JOINT MATERIAL**. Each device shall be sized per the engineer or per manufacturer's recommendations. When the skew of an expansion device exceeds 30 degrees, the engineer shall consider the effects of racking when sizing the device. Expansion joint (Gland), also known as strip seal expansion devices, and modular expansion joints require the use of **SNOW PLOW PLATES**. The sketch below shows the minimum clearances required to size the plates and angles. Steel rails dimensions differ between manufacturers and shall be considered in details. For details of some of these devices, see the examples at the end of this section and Section 4.14 - Approach Slabs, and Section 4.22 - Maintenance and Rehabilitation.

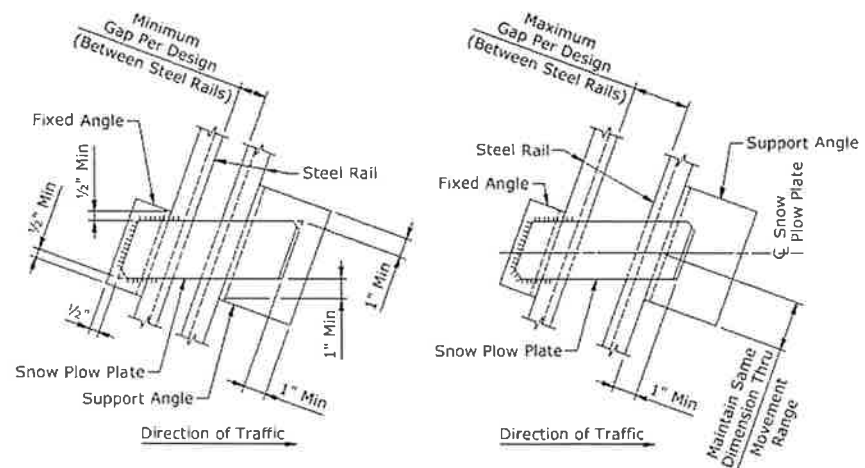

SKETCH FOR SNOW PLOW PLATE ASSEMBLY SIZING

## General Design and Detail Information Concrete Girders

Currently, prestressed-precast concrete sections are used for off-system bridges (when requested and feasible) and for bridges requiring minimum on-site construction time. The Bridge Program selects a girder size and shape based on clearances, span lengths, and fabricator proximity to the construction site, and selects the lengths and spacing of the girders. Concrete used in the girders will have a compressive strength,  $f_c$ , greater than or equal to 5000

psi. The fabricator designs the size, placement, and number of reinforcing steel/prestressing strands in the girder; the type and number of anchorages between the girder and the sole plate (as required); and the girder camber.

The following table gives the number of I-girders and the I-girder spacing to be used with curbs. If a sidewalk is used, the number of girders and spacing will require modification.

<b>Bridge Railing Type : TL3&amp;4 – NCHRP350 Curb Width : 1'-8"</b>				
<b>Table of Girder Spacing</b>				
Clear Roadway Width	Out-Out Width	Number of Girders	Girder Spacing (C-C)	Cantilever
16'-0"	19'-4"	3	7'-0"	2'-8"
20'-0"	23'-4"	3	8'-0"	3'-8"
22'-0"	25'-4"	3	9'-0"	3'-8"
26'-0"	29'-4"	4	7'-6"	3'-5"
28'-0"	31'-4"	4	8'-0"	3'-8"
30'-0"	33'-4"	4	8'-6"	3'-11"
32'-0"	35'-4"	4	9'-0"	4'-2"
34'-0"	37'-4"	5	7'-6"	3'-8"
36'-0"	39'-4"	5	8'-0"	3'-8"
38'-0"	41'-4"	5	8'-6"	3'-8"
40'-0"	43'-4"	5	9'-0"	3'-8"
42'-0"	45'-4"	5	9'-6"	3'-8"

Bridge Railing Type : TL4 - MASH Curb Width : 1'-3 1/2" *				
Table of Girder Spacing				
Clear Roadway Width	Out-Out Width	Number of Girders	Girder Spacing (C-C)	Cantilever
26'-0"	28'-7"	4	7'-6"	3'-0 1/2"
28'-0"	30'-7"	4	8'-0"	3'-3 1/2"
30'-0"	32'-7"	4	8'-6"	3'-6 1/2"
32'-0"	34'-7"	4	9'-6"	3'-0 1/2"
34'-0"	36'-7"	5	7'-6"	3'-3 1/2"
36'-0"	38'-7"	5	8'-0"	3'-3 1/2"
38'-0"	40'-7"	5	8'-6"	3'-3 1/2"
40'-0"	42'-7"	5	9'-0"	3'-3 1/2"
42'-0"	44'-7"	5	9'-6"	3'-3 1/2"

\*Note: Curb width includes 1 1/2" slab extension beyond RF of the curb.

**END DIAPHRAGMS** are required on all concrete superstructures in accordance with AASHTO specifications. **INTERMEDIATE DIAPHRAGMS** will not be required for spans less than or equal to 40'-0". One diaphragm at midspan will be required for spans greater than 40'-0" and less than 80'-0". Two diaphragms at third-points will be required for spans greater than or equal to 80'-0". Diaphragms will be placed parallel to the substructures for skews less than or equal to 20 degrees and normal to the girders for skews greater than 20 degrees. If the diaphragms are placed normal to the girders, they should not be staggered but kept in one straight line with the exterior girders being braced within the middle third of the span. Diaphragms should extend downward to the top of the bottom flange haunch. Intermediate diaphragms may be either concrete or steel.

At bents/piers, No. 6 reinforcing steel bars or prestressing strands should be extended to tie the precast member to the cast-in-place diaphragms at the substructures.

<b>Table Of Reinforcing Bars Or Strands Extended</b>	
<b>I-Girder Type</b>	<b>Number of No. 6 Reinforcing Bars or Strands Extended</b>
AASHTO 1 & 2	4
AASHTO 3 & 4	6
Montana A	6
Montana 10	8
Rocky Mt G-54, G-68, & G-72	8
Minnesota 63	8
AASHTO 5	8

The coefficient of thermal expansion for use on concrete superstructures shall be  $6.0 \times 10^{-6}$  per degree Fahrenheit. The temperature ranges for concrete superstructures are shown below. The movements will be determined from a base temperature of 60 degrees Fahrenheit.

For LRFD: Temperature Range = 5° F to 105° F

For LFD or ASD: Temperature Range = 15° F to 95° F

**END BLOCKS** will be shown for all members greater than 54" deep with a web thickness less than 8".

The **PLAN OF SUPERSTRUCTURE** is a diagram defining the location and orientation of diaphragms and substructures in relationship to the girders.

A **PRESTRESSED-PRECAST GIRDER SECTION** shall be detailed showing the dimensions of the typical assumed girder section.



**Cells**

<b>Name</b>	<b>Description</b>
ABRGBSPWF	Abut Bearing w/ Bevel Sole Plate, Wide Flange
ABRGBSPWP	Abut Bearing w/ Bevel Sole Plate, Welded Plate
ABRGWF	Abut Bearing Wide Flange
ABRGWP	Abut Bearing Welded Plate
DIAPHR	Section through Bent Plate Diaphragm
EXPANGLE	Angle Weld/Cut Details
EXPSEC1	Exp Dev Section at Slab
EXPSEC2	Exp Dev Section at Sidewalk
EXPVIEW1	Exp Dev View at Curb
EXPVIEW2	Exp Dev View at Sidewalk
GRTKEY	Grouted Keyway Detail
KEEPERBAR	Keeper Bar Detail
NUTHX	7/8" Hex Nut
NUTPL	7/8" Hex Nut Plan
NUTSQ	7/8" Hex Nut
OPTSPWF	Opt Shop Splice Detail, Wide Flange
OPTSPWP	Opt Shop Splice Detail, Welded Plate
SHEAR	Shear Connector Details
SSCM2	Strip Seal SSCM2 Rails
STFSEC	Section Through Skew Stiffener
STFWFH	Stiffener Details WF Horizontal
STFWFV	Stiffener Details WF Vertical
STFWPH	Stiffener Details WP Horizontal
STFWPV	Stiffener Details WP Vertical
STWDWF	Stiffener Weld Detail WF
STWDWP	Stiffener Weld Detail WP
STWWP2	Stiffener Weld Detail WP Skew
SUPRTK	K-Frame Slab Support Beam
SUPRTX	X-Frame Slab Support Beam
SWEDGE	Swedge Bolt Detail
WBEV	Bevel Weld
WBEVFL	Bevel Fillet Weld Convex Contour
WBEVG	Bevel Weld Ground Contour
WBL1AS	Web Weld AWS B-L1a-S
WBL2CS	Flange Weld AWS B-L2c-S
WBUTT	Butt Weld Ground Contour
WFIL	Single Fillet Weld
WFIL2	Double Fillet Weld SAW
WFLAGL	Field Weld Flag Left
WFLAGR	Field Weld Flag Right
WFLARE	Flare-Bevel-Groove Weld
WLDTIE	Weld Tie Connection Details

WROUND	Weld All Around Symbol
WTACK	Tack Weld
WTCP4	Bevel Fillet Weld AWS TC-P4
WTCU4C	Bevel Fillet Weld w/Backing AWS TC-U4c
WVC	V Weld Convex Contour
WVG	V Weld Ground Contour

## Welded Plate Girder Checklist

### Framing Plan

- Centerline Girder/Bridge Roadway/Bent/Pier/Field Splice
- Centerline Bearing at Abutment (other than cap-type abutments)
- Working Line/Construction Line Call-out
- Skew and Complement
- Girder/Stiffener Spacing
- Field Splice Locations
- Longitudinal Dimensions
- Curved Girder Radii
- RF Abutment/End of Girder Call-out
- Stiffener/Diaphragm/Cross Frame/Bottom Lateral Bracing Call-out
- Girder No./Diaphragm No./Field Splice No./Bottom Lateral Bracing No./  
Bay No./Longitudinal Stiffener No.
- Stiffeners and Diaphragms/Cross Frames Orientation
- See Detail X Call-outs
- Line Styles
- Longitudinal Dimensions (under title)

### Girder Elevation

- Detail Projected from an Interior Girder on Framing Plan
- Stiffeners Orientation
- Detail Stiffeners/Girder Ends/Holes Adjusted for Grade
- Centerline Bent/Pier/Field Splice/Girder End Holes
- Centerline Bearing at Abutment (other than cap-type abutments)
- Web Thickness and Depth/Top Flange Thickness and Width/  
Bottom Flange Thickness and Width (show steel grade if more than  
one grade is used in the girders)
- Shear Connector Spacing
- Girder Piece Lengths
- Field Splice Locations
- Longitudinal Dimensions
- Girder End Holes Spacings/Call-out
- RF Abutment/End of Girder Call-out
- Optional Shop Splice/Sole Plate/Longitudinal Stiffener Call-outs
- Stiffener Location No./Field Splice No./Longitudinal Stiffener No.
- Welds
- Line Styles

**Web Cutting Diagram**

- Centerline Abutment/Bent/Pier/Field Splice
- Centerline Bearing at Abutment (other than cap-type abutments)
- Ordinate Spacing Along Chord
- Level Dimensions
- Ordinate Dimensions Perpendicular to Chord
- Vertical Dimensions Between Chord and Level Line (blocking ordinate)
- Top of Web Call-out/Top and Bottom of Web Plate are Parallel
- Chord Between Blocking Ordinates Call-out
- Level Call-out
- End of Girder Call-out
- Line Styles
- Includes Dead Load Deflection and Grade (under title)

**Longitudinal Stiffener Details**

- Centerline Girder/Stiffener/Bent/Pier/Field Splice
- Dimensions from End of Longitudinal Stiffeners to Centerline  
Transverse Stiffeners/Field Splices
- Bevel/Dimension at Ends
- Longitudinal Stiffener Call-out
- Optional Shop Splice Call-out
- Welds
- Line Styles/Patterning
- Number Required (under title)

**Bottom Lateral Bracing Details**

**Typical Plan**

- Centerline Girder/Stiffener
- Gusset Plate Dimensions/Clip
- Hole Spacing/Location
- Bevels
- Bottom Lateral Bracing/Gusset Plate Call-outs
- Bottom Lateral Bracing No./Girder No.
- Welds
- Section Symbols
- Line Styles
- Number Required (under title)

**Detail of Flange End Cut at Skewed Abut**

- Centerline Girder
- Bevel
- Centerline Girder to Start of Cut Dimension
- Line Styles

**Bearing Details at Bents/Piers/Non Cap-type Abutments**

**Elevation**

- Centerline Abutment/Bent/Pier
- RF Abutment Call-out (use w/beveled plates)
- Pad/Plate Dimensions
- Slot Location/Size
- Plate Call-out w/Thickness, Height, and Length
- Pad Call-out w/Thickness, Height, and Length/Number of Shims, Thickness, and Location
- Welds
- Direction Arrow (use w/beveled plates)
- Section Symbols
- Line Styles/Patterning

**Section**

- Centerline Girder
- Pad/Plate Dimensions
- Slot Location
- Nut Clearance
- Bolt Call-out/Set with Adhesive Anchorage System
- Line Styles/Patterning
- Number Required (under title)

**Bearing Details at Cap-type Abutments**

**Section**

- Centerline Girder
- Pad/Plate Dimensions
- Bevel Sole Plate Call-out
- Pad Call-out w/Size
- Line Styles/Patterning
- Number Required (under title)

**Elevation (with bevel sole plate)**

- RF Abutment Call-out
- Bevel Sole Plate Thicknesses
- 1/2" Dimension
- Bevel Sole Plate Call-out w/Size
- Pad Call-out
- Welds
- Patterning

**Miscellaneous**

- Transverse Stiffener Details
- Stiffener Clip and Weld Detail
- Shear Connector Detail
- Girder End Bevel Detail
- Optional Shop Splice Detail
- Alternate Weld Connection Detail
- Keeper Plate Detail
- Swedge Bolt Detail

**Notes**

- Optional Shop Splice/Ultrasonic Testing
- Shear Connectors Are Intended to be Field Installed
- Bolt Hole Edge Distance
- Stiffeners/Girder Ends/Holes in Girder Web Placed Vertical
- Indicated Weld Not AISC Required

## **Rolled Beam (Wide Flange) Girder Checklist**

### **Framing Plan**

- Centerline Girder/Bridge Roadway/Bent/Pier/Field Splice
- Centerline Bearing at Abutment (other than cap-type abutments)
- Working Line/Construction Line Call-out
- Skew and Complement
- Girder/Stiffener Spacing
- Field Splice Locations
- Longitudinal Dimensions
- Curved Girder Radii
- RF Abutment/End of Girder Call-outs
- Stiffener/Diaphragm/Cross Frame/Call-outs
- Girder No./Diaphragm No./Field Splice No./Bay No.
- Stiffeners and Diaphragms/Cross Frames Orientation
- See Detail X Call-outs
- Line Styles
- Longitudinal Dimensions (under title)

### **Girder Elevation**

- Detail Projected from an Interior Girder on Framing Plan
- Stiffeners Orientation
- Detail Stiffeners/Girder Ends/Holes Adjusted For Grade
- Centerline Bent/Pier/Field Splice/Girder End Holes
- Centerline Bearing at Abutment (other than cap-type abutments)
- Shear Connector Spacing
- Girder Piece Lengths
- Field Splice Locations
- Longitudinal Dimensions
- Girder End Holes Spacings/Call-out
- W-Beam Call-out
- RF Abutment/End of Girder Call-outs
- Optional Shop Splice/Sole Plate Call-outs
- Stiffener Location No./Field Splice No.
- Line Styles
- Longitudinal Dimensions (under title)

**Blocking Diagram**

- Centerline Abutment/Bent/Pier/Field Splice
- Dimensions along Bottom Flange
- Ordinate Dimensions
- Level Dimensions
- End of Girder Bevel Cut Dimensions (if not in a separate detail)
- W-Beam Call-out
- Level Call-out
- End of Girder Call-out
- Line Styles

**Diaphragm Details**

**Typical Sections**

- Centerline Girder/Bridge Roadway
- Girder Spacing
- Hole Spacing/Location
- Vertical Offset Between Girders
- Bent Plate Call-out w/Thickness, Width, and Length
- Line Styles/Patterning
- Section/Dimensions Orientation (under title)
- Number Required (under title)

**Typical Section Thru Bent Plate**

- Width/Depth/Radius Dimensions
- Bent Plate Call-out
- Patterning

**Diaphragm Elevation (for sloped diaphragms)**

- Vertical and Horizontal Dimensions
- Bent Plate Call-out

**Field Splice Details**

- Centerline Girder/Field Splice
- Hole Spacing/Locations
- Gap Dimension
- Plate/Bar Call-outs w/Size
- Section Symbols
- Line Styles
- Number Required (under title)



**Detail of Girder End at Abutment**

- Centerline Abutment/Girder
- Centerline Bearing at Abutment (other than cap-type abutments)
- Skew and Complement
- Dimensions
- RF Abutment Call-out
- Bearing Pad Call-out
- End of Girder Call-out
- Bevel Sole Plate Call-out
- Line Styles/Patterning

**Detail of Skewed Intermediate/Bent/Pier/ Stiffeners**

- Centerline Girder/Stiffener/Bent/Pier
- Centerline Bearing at Abutment (other than cap-type abutments)
- Skew and Complement
- Stiffener Lengths Along Long Side/Short Side
- Dimension from Centerline Girder to Hole
- Line Styles/Patterning

**Detail of Flange End Cut at Skewed Abut**

- Centerline Girder
- Bevel
- Centerline Girder to Start of Cut Dimension
- Line Styles

**Bearing Details at Bents/Piers/Non Cap-type Abutments**

**Elevation**

- Centerline Abutment/Bent/Pier
- RF Abutment Call-out (use w/beveled plates)
- Pad/Plate Dimensions
- Slot Location/Size
- Plate Call-out w/Thickness, Height, and Length
- Pad Call-out w/Thickness, Height, and Length/Number of Shims, Thickness, and Location
- Welds
- Direction Arrow (use w/beveled plates)
- Section Symbols
- Line Styles/Patterning

**Bearing Details at Bents/Piers/Non Cap-type Abutments (Cont'd)**

**Section**

- Centerline Girder
- Pad/Plate Dimensions
- Slot Location
- Nut Clearance
- Bolt Call-out/Set with Adhesive Anchorage System
- Line Styles/Patterning
- Number Required (under title)

**Bearing Details at Cap-type Abutments**

**Section**

- Centerline Girder
- Pad/Plate Dimensions
- Bevel Sole Plate Call-out
- Pad Call-out w/Size
- Line Styles/Patterning
- Number Required (under title)

**Elevation (with bevel sole plate)**

- RF Abutment Call-out
- Bevel Sole Plate Thicknesses
- 1/2" Dimension
- Bevel Sole Plate Call-out w/Size
- Pad Call-out
- Welds
- Patterning

**Miscellaneous**

- Transverse Stiffener Details
- Stiffener Clip and Weld Detail
- Shear Connector Detail
- Optional Shop Splice Detail
- Girder End Bevel Detail
- Keeper Plate Detail
- Swedge Bolt Detail

**Notes**

- No Camber Required
- Shear Connectors Are Intended to be Field Installed
- Bolt Hole Edge Distance
- Stiffeners/Girder Ends/Holes in Girder Web Placed Vertical
- Indicated Weld Not AISC Required
- Dimensions Measured Along Centerline Girder (curved girders)

# **Prestressed-Precast Concrete Bulb T Girder Checklist**

## **(Tri-Deck and Twin T Girders similar)**

### **Plan**

- Centerline Girder Web/Bridge Roadway/Bent/Pier/Structure/  
Intermediate Diaphragm/Weld Tie
- Skew and Complement
- Girder Web Spacing
- Diaphragm/Weld Tie/Curb Tie Bar Spacing
- Girder Length
- Longitudinal Dimensions
- Clear Roadway/Curb/Sidewalk/Out-to-Out Dimensions
- Corbel Length
- Corbel Reinforcing Spacing/Call-out
- Curb Longitudinal Reinforcing/Typ Row Call-out
- RF Abutment/End of Girder Top Flange/Weld Tie Call-outs
- Diaphragms Orientation
- Line Styles

### **Intermediate/Bent/Pier Steel Diaphragm Details**

#### **Section at Diaphragm**

- Centerline Bridge Roadway
- Bolt Hole/Slot Spacing/Location
- Channel Member Call-out w/Length
- Bar/Plate Call-out
- Level or Angle to Stem Call-out
- Section Symbols
- Line Styles/Patterning

#### **Section thru Diaphragm/Connection Plate**

- Centerline Diaphragm
- Bolt Hole/Slot Spacing/Location
- Clearances
- Channel Member Call-out
- Bolt/Washer/Hole/Slot Call-outs/Sizes
- Angle Member/Bar/Plate/Sleeve Insert Call-outs w/Lengths
- Line Styles/Patterning

**Girder Sections**

- Centerline Girder Web/Keyway
- Height/Width Dimensions
- Chamfer/Cont Notch Call-outs
- See Keyway Detail
- Line Styles/Patterning

**Bearing Details**

**Plan**

- Centerline Abutment/Girder Bottom Flange
- Skew and Complement
- Dimensions
- RF Abutment Call-out
- Bearing Pad Call-out
- Line Styles/Patterning

**Section (end view)**

- Centerline Girder Web
- Pad/Plate Dimensions
- Line Styles/Patterning
- Number Required (under title)

**Section at End Diaphragm**

- Centerline Bridge Roadway/Girder Web
- Horizontal Dimensions
- Reinforcing Size/Spacing/Clearance/Call-outs
- Cross Slope(s) in Percent
- See Keyway Details
- See Railing Anchorage Details
- Line Styles/Patterning

**Typical Sections thru End Diaphragm**

**Section at Girder Web**

- Centerline Sleeve Insert
- Corbel Dimensions
- End of Top Flange/Bottom Flange Location
- Sleeve Insert Spacing/Location
- Sleeve Insert Call-out/Size/Fill with Nonshrink Grout
- Prestressing Strand Call-out/Spacing/Extension/Number Required
- Abutment Stirrup/Tie Bars
- RF Abutment/Tooled Edge Call-outs
- End of Girder Web/Top Flange/Bottom Flange Call-outs
- Line Styles/Patterning
- Showing Typical Dimensions (under title)

**Section Between Girder Webs**

- Reinforcing Size/Spacing/Location/Clearance/Call-outs
- Line Styles/Patterning
- Showing Typical Reinforcing Steel (under title)

**Bridge Railing Anchorage Details**

**Section at Post**

- Bolt/Pipe Location
- Block Out Dimensions
- Reinforcing Size/Location/Clearance/Call-outs
- Bolt/Rod Call-out
- Plate/Pipe Call-outs/Place Flush
- Section Symbols
- Line Styles/Patterning

**Section thru Anchorage**

- Centerline Post
- Reinforcing Size/Location/Call-outs
- Pipe Call-out
- Line Styles/Patterning
- Bolts Not Shown (under title)

**Plate Detail**

- Centerline Pipe/Hole/Post
- Plate Dimensions
- Plate/Hole Call-outs/Sizes
- Pipe Call-out/Size/Tack Weld
- Line Styles/Patterning
- Bolts and Deck Not Shown (under title)

**Miscellaneous**

- Weld Tie Detail
- Anchor Rod Detail
- Keyway Detail
- Corbel Reinforcing Detail
- Typical Curb Section
- Bill of Reinforcement

**Notes**

- Top Flange Reinforcing Steel Coated
- Ensure Slab Bars Extend
- Ensure Prestressing Strands Are Evenly Spaced and Extended
- Backer Rod Continuous
- Reinforcing Steel Marked Not Included in Quantity
- Reinforcing Steel Prefix
- Attain 100% of Ultimate Design Strength
- Concrete Quantity

## **Expansion Joint (Gland) Checklist**

### **Plan**

- Centerline Bridge Roadway/Snow Plow Plate
- Working Line/Construction Line Call-out
- Complement
- Direction of Traffic
- Curb to Curb Length
- Stud/Snow Plow Plate Spacing/Orientation
- FF Curb/Sidewalk Call-out
- FF Curb/Sidewalk at RF Steel Rail Call-out (if skewed)
- RF Abutment Call-out
- Steel Rail/Miter Joint in Steel Rail/Steel Rail Joint Call-outs
- Stud Call-out/Field Bend to Maintain 2" Clearance
- Section Symbols
- Line Styles

### **Snow Plow Plate Assembly Detail**

- Centerline Snow Plow Plate
- Skew
- Direction of Traffic
- Width/Length/Location Dimensions
- Snow Plow Plate/Angle Members/Steel Rail/Bevel Call-outs
- Welds/No Welds
- Line Styles
- Gland Not Shown Note (under title)

### **Plan at Sidewalk Cover Plate**

- Centerline Anchorage System/Holes
- Plate/Angle Member/Bar Dimensions
- Anchorage System/Hole Spacing/Location
- Plate/Angle Member/Bar/Bevel Call-outs
- RF Abutment/FF Sidewalk Call-outs
- Section Symbols
- Line Styles
- Cap Screw Not Shown Note (under title)



**Miscellaneous**

- Typical Section (at snow plow plate)
- Typical Section at Sidewalk
- View at Curb
- Angle Cut Detail(s)
- Angle Weld Detail
- Snow Plow Plate Detail (if skewed)

**Notes**

- Install Snow Plow Plates Parallel with Grade
- Do Not Start Subsequent Welds
- Sidewalk Cover Plate Anchorage System Consists Of
- Field Weld Steel Rails at Joint