

TYPE 1 GRATE

APPROX. WT. 420 LBS. [191 kg]

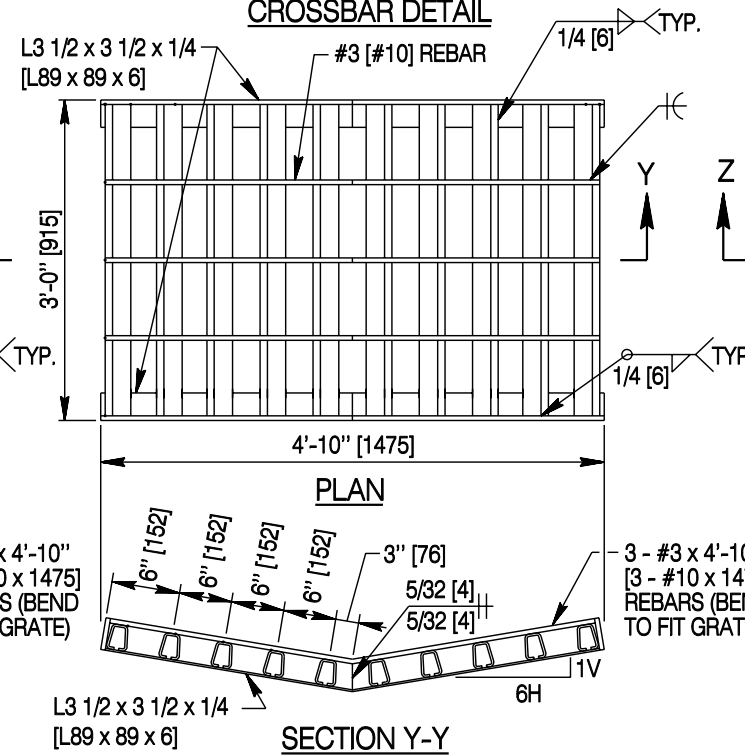

TYPE 2 GRATE

APPROX. WT. 230 LBS. [104 kg]

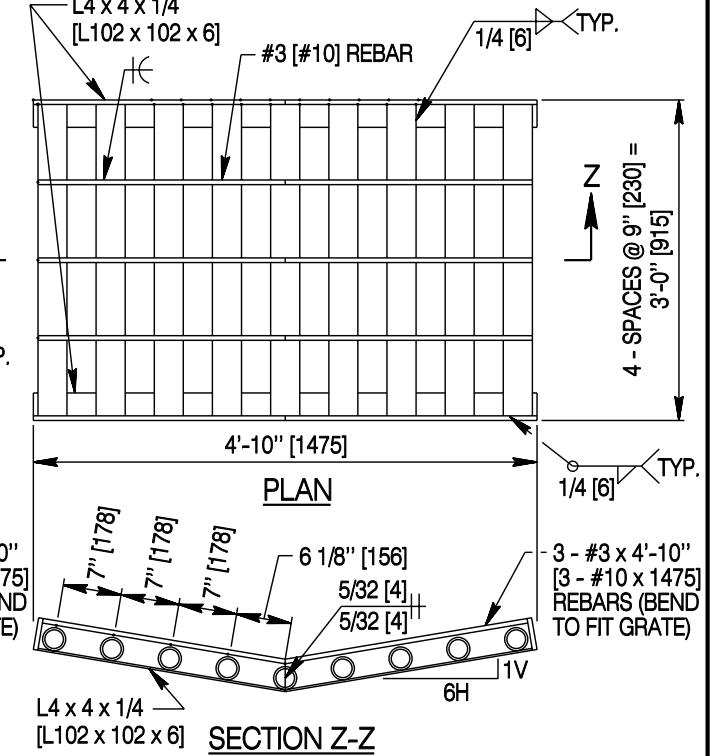

TYPE 3 GRATE

APPROX. WT. 270 LBS. [122 kg]

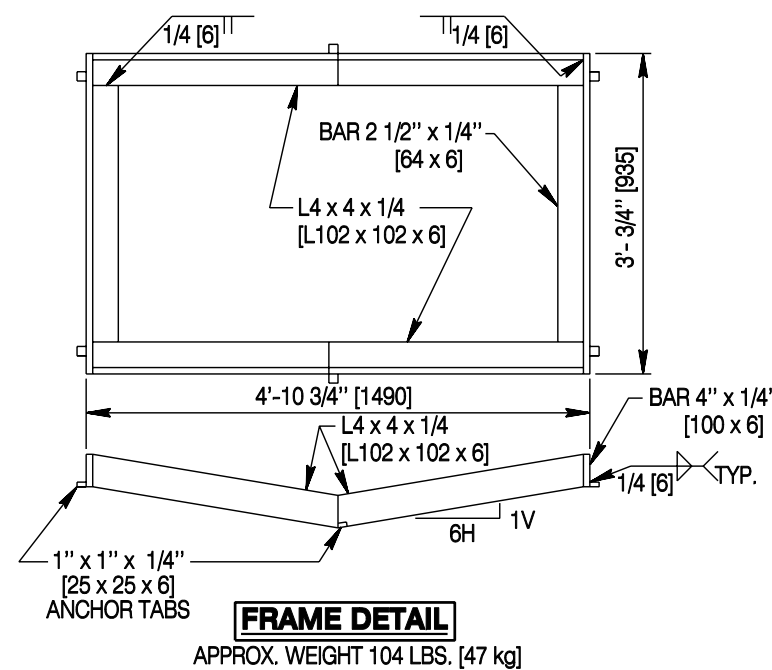

APPROX. WEIGHT 104 LBS. [47 kg]

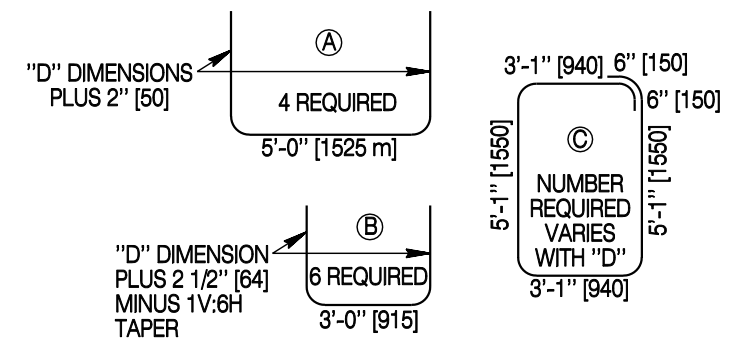

BENDING DIAGRAMS
DIMENSIONS ON BENDING DIAGRAMS ARE OUT TO OUT.

GENERAL NOTES

Reinforcing Bars
Space #4 [#13] rebar at 12 in [305] centers in walls and bottom of box.

Designed by: CRR
Drawn by: GLD
Checked by: RRC
Previous Desg. No. 625-01A

Note: Units shown in brackets [] are metric and are in millimeters (mm) unless other units are shown.



INLET TYPE M1 FOR MEDIAN DRAINS

STANDARD PLAN

STANDARD PLAN NUMBER
625-1
SHEET 1 of 1
Issued by: ENGINEERING SERVICES
Date Issued: NOVEMBER, 2004
FILE: j:\StanDual_Std_Wrk6251_01.dgn