

Wyoming Department of Transportation



Signing Manual



Traffic Program
Design and Operations
September 2018

Introduction

The purpose of this manual is to serve as a guide for The Wyoming Department of Transportation and Consultants engaged in the practice of designing and placing Roadside Signs on the State Highway System. The concepts in this manual can also be used for local roads not falling within State jurisdiction.

This manual is intended to provide statewide standardization and consistency for the design and placement of primary and secondary signs. Information contained in this manual is to establish basic guidelines for the design of highway signing. The information herein is intended to support and complement sound engineering judgment.

This manual is not intended to be a stand-alone document that contains everything a person needs to know to develop a sign design plan. Unique circumstance will be encountered that cannot be discretely addressed. In these instances prudence and sound engineering judgment must be used. If further assistance is required, contact the Headquarters Traffic office for further discussion and guidance.

All information included in this manual is in compliance with the Manual on Uniform Traffic Control Devices (MUTCD).

The following six rules will be followed without exception:

- 1) No commercial advertising is allowed on sign or support. Exceptions include logo and trailblazer signing within Specific Service Signing.
- 2) Any sign placed within the Right of Way without the Wyoming Department of Transportation's authority will be considered a nuisance and will be removed.
- 3) Non-essential signing will be removed as it degrades the value of necessary signing.
- 4) Signing within the Right of Way will be erected by the Wyoming Department of Transportation unless otherwise approved.
- 5) The District Traffic Engineer will provide approval to any change in traffic control devices.
- 6) Any major change to traffic control devices will require the approval of Headquarters Traffic Program.

Table of Contents

1 – Signing Basics.....	1.1
1A – Sign Types.....	1.1
1B – Signing Principles.....	1.1
1C – Sign Spacing.....	1.2
1D – Sign Size.....	1.2
2 – Regulatory Signs.....	2.1
2A – General.....	2.1
2B – Stop and Yield Signs.....	2.1
2C – Speed Limit Signs.....	2.1
2D – Lane-Use Control Signs.....	2.2
2E – One-Way Signs.....	2.2
2F – Median Crossover Signs.....	2.2
3 – Warning Signs.....	3.1
3A – General.....	3.1
3B – Stop, Yield, or Signal Ahead.....	3.1
3C – Reduced Speed Ahead.....	3.2
3D – Clearance Sign for Bridges and Other Overhead Objects.....	3.2
3E – Curve Signs and Chevron Signs.....	3.2
4 – Guide Signs.....	4.1
4A – General.....	4.1
4B – Interstate to Interstate Advance Guide Signs.....	4.1
4C – Major Interchange Advanced Guide Signs.....	4.1
4D – Minor Interchange Advance Guide Signs.....	4.2
4E – Interstate to Interstate Intersection Signs.....	4.2
4F – Major Intersection Guide Signs.....	4.2
4G – Minor Intersection Guide Signs.....	4.2
4H – Distance Signs Located on Interstate Highways.....	4.3
4I – Distance Signs Located on Non-Interstate Highways.....	4.3
4J – Control City Signing.....	4.4
5 – Signing Materials.....	5.1
5A – Substrate.....	5.1
5B – Background Sheeting.....	5.1
5C – Sign Legend.....	5.1
5D – Additional Requirements.....	5.2
6 – Sign Supports and Foundations.....	6.1
6A – Timber Posts.....	6.1
6B – Round Tubular Posts.....	6.5
6C – Perforated Square Tubular Posts.....	6.8
6D – I-Beam Breakaway Steel Posts.....	6.11

7 – Lateral Clearance and Mounting Height.....	7.1
7A – Lateral Clearance and Mounting Height.....	7.1
7B – Ramps and Crossroads.....	7.1
7C – Non-Interstate Highways.....	7.2
7D – Urban and Sections with Curb and Gutter.....	7.3
7E – Barrier Protected Roadway Sections.....	7.3
7F – Chevron Signing for Curves.....	7.4
8- Post Length Determination.....	8.1
8A – Embedment Depth.....	8.1
8B – Mounting Height.....	8.1
8C – Offset Height.....	8.1
8D – Post Length Behind Signs.....	8.3
9 – Hardware and Backing Angles.....	9.1
9A – Backing and Clip Angles.....	9.1
9B – Hardware.....	9.2
10 – Reference Markers.....	10.1
10A – Location and Spacing of Reference Markers.....	10.1
10B – Interstate Highways.....	10.1
10C – Non-Interstate Highways.....	10.1
10D – Materials.....	10.1
11 – Overhead Sign Structures.....	11.1
12 – District Sign Upgrades.....	12.1
13 – Shop Drawing Review.....	13.1
14 – Sign Inspection.....	14.1
Appendix A – Intersection and Junction Signing.....	A.1
Figure A-1 – Interstate Diamond Interchange with Two Lane Crossroad.....	A.1
Figure A-2 – Interstate Diamond with Multilane Crossroad.....	A.2
Figure A-3 – Minor Interchange Crossroad.....	A.3
Figure A-4 – Highway Junction.....	A.4
Figure A-5 – Interchange Off Ramp County/Local Road.....	A.5
Figure A-6 – Interchange Off Ramp Non-NHS Crossroad.....	A.5
Figure A-7 – Interchange Off Ramp NHS Crossroad.....	A.6
A-8 – Sequence of Signs.....	A.6
Appendix B – Typical Signing Notes.....	B.1
B-1 – Permanent Signing Notes.....	B.1
B-2 – Sign Summary Notes.....	B.2
B-3 – Traffic Control Notes.....	B.3

1 – Signing Basics

1A – Sign Types

Effective signing provides drivers with concise information enabling them to make safe, timely, and predictable decisions. Sign spacing and the amount of information displayed impacts the driver's ability to read and respond to messages.

The primary function of a highway sign is to inform drivers of regulations, warn of unexpected conditions that may be encountered, and to provide guidance to major destinations. Examples of primary signs include:

Regulatory Signs: Regulatory signs are used to inform drivers of regulations concerning the operation of vehicles on the highway (i.e.; stop, yield, speed limit, etc). Regulatory sign colors are black and white, red and white, or a black/red/white combination.

Warning Signs: Warning signs are used to advise the driver of unexpected highway conditions on or adjacent to the roadway (i.e.; curve, stop ahead, chevrons, etc.). Warning sign colors are yellow and black.

Advanced Guide Signs: Guide signs are used in directing the driver to destinations along established routes (i.e.; intersection, exit direction, etc.). Advanced guide signs colors are green and white.

The secondary function of a highway sign is to advise drivers of available services, inform drivers of recreational and cultural activities, and to provide guidance to a secondary destination. Examples of secondary signs include:

Motorist Services Signs: Motorist service signs advise and direct the driver to basic services that are needed to complete a long trip (i.e.; gas, food, lodging, rest areas, truck parking, etc.). Motorist service sign colors are blue and white.

Supplemental Guide Signs: Supplemental guide signs provide the driver with additional information pertaining to the route or in some instances a geographical reference, although not directly necessary for travel (i.e.; mileage, route marker, community colleges, county lines, etc.). Supplemental guide sign colors are green and white.

Recreational and Cultural: Recreational and cultural signs inform the drivers of sites that may be of personal interest or value (i.e.; museums, state parks, historical sites, etc.). Recreational and cultural sign colors are brown and white.

1B - Signing Principles

Ensure that the design (size, shape, and color) of highway signs conforms to the MUTCD. Emphasis must be placed on uniformity of highway signing. Standard designs for signs have been adopted in the MUTCD to provide uniformity of the message and recognition by drivers. This uniformity includes standard shapes, colors, legends, and symbols. Symbols are only useful if the driver can understand them.

A traffic sign should be installed only if it fulfills a specific need, this increases the signs credibility. An effective sign should have attention value, a clear simple message, and be located so drivers have adequate time to see, comprehend, and respond.

Information overload and loss of credibility is a result of too many signs, nonessential signs, compressed spacing between signs, inconspicuity or legibility.

Regulatory and warning signs should be used conservatively because these signs, if used to excess lose effectiveness. Route signs and directional guide signs should be used frequently because their use promotes efficient operations by keeping road users informed of their location.

The priority for sign placement is as follows:

1. Regulatory
2. Warning
3. Guide

The locations of regulatory signs should be considered first, followed by warning sign locations, and finally the location of guide signs.

1C - Sign Spacing

Interstate Highways: Spacing between mainline interstate signs should be a minimum of 750 feet. Longitudinal spacing on ramps is recommended at 250 feet but can be a minimum of 100 feet.

Non-Interstate Highway: Spacing between signs on rural non-interstate highways should be a minimum 500 feet.

Urban Areas: Spacing between signs on urban roadway sections is recommended to be 3 times the speed limit in mph, thus, in a 45 mph zone a 135 foot spacing may be used. Due to limited space in urban areas this often times cannot be met. Signing priority and need should be carefully considered in such situations

1D - Sign Size

Standard sign size is covered by the MUTCD. There are instances when larger than standard size **may** be used. These instances are as follows:

- 1) Sight Restriction
- 2) Sign Visibility or Conspicuity
- 3) Crash Experience
- 4) Complaints or Near Misses

Before increasing standard sign sizes the following should be given consideration:

- 1) Addition of another sign (i.e.; stop ahead)
- 2) Doubling the signs, one on each side of the road
- 3) Addition of a flashing beacon or flags
- 4) In the case of a warning sign, using fluorescent yellow sheeting.

2 - Regulatory Signs

2A - General

Size

The dimensioning of regulatory signs is prescribed by Table 2B-1 in the MUTCD. These tables are used unless engineering judgment determines another size is appropriate; other exceptions are listed below.

Font

The font used (size and type) for regulatory signs is standardized and is covered by the Standard Highway Sign and Markings (SHSM) Book.

2B – Stop (R1-1) and Yield (R1-2) Signs

Placement

Place Stop and Yield Signs as near as practical to the point where vehicles are to stop. Lateral placement should be 6 to 12 feet from the edge of pavement or a minimum of 2 feet from the face of curb. In the instance where 12 feet of lateral clearance cannot be met, a stop bar will be required where vehicles are to stop.

Size

Stop signs shall be 48 inches at the intersection of two State highways and at all interchange exit ramps. Use 36" stop signs on all multi-lane highways and 30" stop signs on single lane highways. Yield sign shall be 36 inches in all cases.

Legalese

Stop and yield signs are not mandated by State law at the intersection of State roadways with private roads or driveways or with alleys, driveways, or buildings within a business or residential district (Wyoming Statutes 31-5-223 and 31-5-506).

2C - Speed Limit Signs (R2-1)

Placement

Speed limit signs shall be placed as near as practical where the speed limit changes, at entrances to the state, at jurisdictional boundaries in urban areas, and beyond points where a significant number of vehicles may enter the roadway. Speed limits signs should also be placed at 20 mile intervals on interstate highways and rural highways and 1 to 2 mile intervals on urban sections. All roads two miles or more in length shall have a speed limit sign.

In the event that a speed advisory plaque is required below the curve warning sign, the speed limit sign should be moved away from the curve to avoid conflict with the advisory speed.

Size

Typically, 48 X 60 inch signs are reserved for interstate highways. On non-interstate highways 36 X 48 inch signs are used, however, 48 X 60 inch may be used when greater emphasis is required. In urban areas a 24 X 30 inch sign may be used only where space will not allow a larger size.

2D - Lane-Use Control Signs (R3-5, R3-5a, R3-6, etc.)

Placement

At signalized multi-lane intersections, advanced ground mount signing is required to designate lane usage. Use overhead signing mounted to mast arms at intersections with restricted lane use that are not controlled by a four section signal head. When overhead signing is used, it should be placed over the designated lanes.

Size

Size will vary based on sign configuration.

2E - One-Way Signs (R6-1 and R6-2)

Placement

When a Stop or Yield sign is used in conjunction with a One Way sign (R6-1) the One Way sign should be installed above the Stop or Yield sign.

Size

For all applications One Way Signs (R6-1) shall be 36 X 12 inches. For One Way sign (R6-2) the size shall be 18 X 24 inches. In roundabout applications use a 54 X 18 inch arrow mounted above a 54 X 24 inch R6-4A sign

2F – Median Crossover Signs

Developed median crossovers are signed on construction projects with concurrence from the District Traffic Engineer. Median crossover sign consist of a No U Turn (R3-4) placed above a sign that reads, "EXCEPT AUTHORIZED VEHICLES."

Placement

Longitudinally, these are placed at the end of the taper for the deceleration lane or 400 feet ahead of the turnaround. Transverse placement is determined at the discretion of the designer with the concurrence of the Engineer. This is primarily due to varying median widths and the presence of other obstacles.

Size

Use a 30" X 30" R3-4 and a 30" X 24" for the "Except Authorized Vehicle" sign.

3 - Warning Signs

3A - General

Size

The dimensioning of warning signs is prescribed by Table 2C-2 of the MUTCD. These tables are used unless engineering judgment determines another size is appropriate; other exceptions are listed below.

Font

The font used (size and type) for Warning signs is standardized and is covered by the Standard Highway Sign and Markings (SHSM) Book.

Placement

Unless otherwise noted, place warning signs 750 feet prior to the stated warning. For example, a curve warning sign should be placed at 750 feet prior to the point of curvature.

In the event sight distance is not sufficient to respond and 750 feet is unattainable to set warning signs, the following table may be used to set advanced warning signs:

Table 3-1 Placement of Warning Signs

Speed Limit (MPH)	Distance (Feet)
20	100
25	100
30	100
35	100
40	125
45	175
50	250
55	325
60	400
>60	500

3B – Stop (W3-1), Yield (W3-2), or Signal Ahead (W3-3) Sign

Placement

Stop Ahead or Yield Ahead signs are to be used on all rural State highways and exit ramps. Lateral placement should be 12 feet from the edge of traveled way. In the event that a Stop or Yield sign lateral clearance is exceeded and the sign is difficult to see a Stop Ahead or Yield Ahead sign should be installed and a stop or yield bar is recommended.

Use a Signal Ahead sign when transitioning from a high speed rural highway to the first signal in a lower speed urban area. In addition, use when approaching a signal (or series of signals) in area with posted speed limits greater than 45 mph, this includes off ramps.

On some occasions, it may be appropriate to warn drivers of a change in the type or operation of traffic control at an intersection. In the following cases, a Stop, Yield, or Signal Ahead sign may be used:

- 1) Installation of a new Stop or Yield sign or a new signal
- 2) Change from two-way to all-way stop
- 3) Change from stop control to signal control
- 4) Change from yield control to stop control

Size

When a Stop Ahead sign is used it shall be the same size as the Stop sign. Yield Ahead signs shall always be 36 inches.

3C - Reduced Speed Ahead (W3-5)

Placement

Use reduced speed ahead signs when transitioning from a high speed rural section to a lower speed urban section and the reduction is greater than 10 mph. For speed reductions of 15 mph to 20 mph, place a Reduced Speed Ahead sign 750 feet before the Speed Limit Sign. For speed reductions greater than 20 mph, place a Reduced Speed Ahead sign 1000 to 1500 feet before the Speed Limit Sign.

3D - Clearance Signs for Bridges and Other Overhead Objects (W12-2)

Placement

Use a bridge clearance sign for structures or overhead objects with 19 feet of vertical clearance or less over the roadway. Place the bridge clearance sign 250 feet past the exit gore. In instances where ramps are not present, place bridge clearance signs 750 feet in advance of the structure. When vertical clearance is 16 feet or lower, two signs will be required; place one sign 250 feet past the exit gore and a second sign across from the advanced exit warning sign in the median. In the instance of a structure crossing the roadway with no ramps and a clearance of 16 feet or lower two signs will be required, placed directly across from each other 1000 feet ahead of the hazard.

Size

Use a 48 inch diamond for interstate highways. For crossroads and non-interstate highway use a 30 inch diamond; this may be increased due to speed limit.

3E - Curve Signs and Chevron Signs

Placement

On clover leaf exit ramps or curves with 270 degrees of curvature, use the loop curve sign (W1-15). If the curve is greater than 135 degrees but not a loop, use the hairpin sign curve (W1-11). For advisories of 30 mph or less a turn sign (W1-1) shall be used.

The following equation is used (for design purposes only) to determine the advisory speed of a horizontal curve:

$$AS = \sqrt{15R(0.01e + f)}$$

AS = Advisory Speed (mph)

R = Radius of Curvature (ft)

e = Superelevation (percent)

f = Side Friction Factor (AASHTO 2011, table 3-7)

If the advisory speed given by the above equation is 10 mph or greater below the posted speed limit, place an advisory plaque and curve sign.

Due to potential differences between the design and actual constructed superelevation, it is advisable to confirm the advisory speed using the Ball Bank Method once the roadway is completed. The Wyoming Department of Transportation uses a 10 degree ball bank reading for speeds greater than 25 mph and a 12 degree ball bank reading for speeds 25 mph and less.

The following table illustrates advisory curve signing (W1-2) using a ball bank indicator while driving through a curve with a posted speed limit of 70 MPH. With a posted limit of 65 MPH, the first line would read 63 or more.

Table 3-2 Curve Advisory Using Ball Bank Indicator

Ball Bank (Degrees)	Speedometer Reading (MPH)	Required Advanced Warning Signing
10	≥ 68	None, unless hidden curve
10	63 - 67	Curve Sign - 65 mph advisory optional
10	58 - 62	Curve Sign - 60 mph advisory
10	53 - 57	Curve Sign - 55 mph advisory
10	48 - 52	Curve Sign - 50 mph advisory
10	43 - 47	Curve Sign - 45 mph advisory
10	38 - 42	Curve Sign - 40 mph advisory
10	33 - 37	Curve Sign - 35 mph advisory
10	28 - 32	Curve Sign - 30 mph advisory
12	23 - 27	Curve Sign - 25 mph advisory
12	18 - 22	Curve Sign - 20 mph advisory
12	13 - 17	Curve Sign - 15 mph advisory
12	8 - 12	Curve Sign - 10 mph advisory

Chevrons (W1-8) are used for curves when the advisory speed is 15 mph or less than the posted speed limit. The following table shows chevron spacing as a function of advisory speed:

Table 3-3 Chevron Spacing

Advisory Speed	Chevron Spacing
15 mph or less	40 feet
20 to 30 mph	80 feet
35 to 45 mph	120 feet
50 to 60 mph	160 feet
>60 mph	200 feet

Example:

A horizontal curve with a radius of 700 feet and a superelevation of 8 percent is located on a highway with a posted speed limit of 70 mph.

$$AS = \sqrt{15R(0.01e + f)}$$

$$AS = 43$$

$$R = 700$$

$$e = 8$$

$$f = 0.1 \text{ (AASHTO 2011, table 3-7)}$$

In this instance, design would recommend a curve warning sign with an advisory plaque reading 40 mph. Additional chevrons would be required at a spacing of 120 feet.

However, upon completion of the roadway the road is ball banked at 10 degrees and the speedometer reading is 64 mph. In this instance a curve warning sign is recommended to be placed with no advisory plaque and no chevrons.

4 - Guide Signs

4A - General

Size

The size of distance and destination guide signs is variable because it is dependent on the length of the message, the size of lettering, and the presence (or absence) of any graphical information. For route signs, however, the sizes are fixed and can be found in Section 2D.11 of the MUTCD. The legend to be displayed on a guide sign must be determined first and then the size and style of lettering. Together these will determine the size. The Wyoming Department of Transportation requires the use of the program *Guide Sign* for design.

Font

The following are the Wyoming Department of Transportation's requirements for font and arrow sizing. At times, engineering judgment may be required to modify font size. Careful consideration should be given before a change is made.

4B - Interstate to Interstate Advance Guide Signs

Destination:	Use a mixed case E-modified font. Letter sizing is 20 inches for uppercase and 15 inches for lower case
Distance:	Use an upper case E font. Sizing is 12 inches for letters and 18 inches for numbers.
Shields:	Use a 48 inch shield.
Exit Number:	Use an upper case E font. Sizing is 10 inches for letter and 15 inches for numbers.
Arrows:	Use an 18 inch arrow for ground mounted signs. Use a 24 inch arrow for overhead signs.
Cardinal Direction:	Use an all upper case D font. The first letter will be a minimum 11 inches and the following letter 10 inches.

4C - Major Interchange Advance Guide Signs

Destination:	Use a mixed case E-modified font. Letter sizing is 16 inches for uppercase and 12 inches for lower case.
Distance:	Use an upper case E font. Sizing is 10 inches for letters and 15 inches for numbers.
Shields:	Use a 36 inch shield.
Exit Number:	Use an upper case E font. Sizing is 10 inches for letters and 15 inches for numbers.
Arrows:	Use a 15 inch arrow for ground mounted signs. Use a 18 inch arrow for overhead signs.

Cardinal Direction: Use an all upper case D font. The first letter will be a minimum 11 inches and the following letters 10 inches

4D - Minor Interchange Advance Guide Signs

Destination: Use a mixed case E-modified font. Letter sizing is 13.33 inches for uppercase and 10 inches for lower case.

Distance: Use an upper case E font. Sizing is 8 inches for letters and 12 inches for numbers.

Shields: Use a 36 inch shield if required. Typically shields are not required.

Exit Number: Use an upper case E font. Sizing is 10 inches for letter and 15 inches for numbers.

Arrows: Use a 15 inch arrow for ground mounted signs. Use a 18 inch arrow for overhead signs.

Cardinal Direction: Typically cardinal directions are not used on minor interchanges.

4E - Interstate to Interstate Intersection Signs

Typically interstate to interstate intersections are not signed for guidance. This is because the driver cannot make a turn (left or right) at the intersection.

4F - Major Intersection Guide Signs

Destination: Use a mixed case D font. Letter sizing is 8 inches for upper case and 6 inches for lower case.

Distance: Typically, distance to destination is not given.

Shields: Use 24 inch shields.

Arrows: Use 10 inch arrows. For multiple destinations; destinations will be separated with a line, destinations requiring forward and left arrows will be placed above destinations requiring right arrows. Left and forward arrows will be placed to the left of the destination, right arrows will be placed on the right of the destination. For single destinations the arrow is always below.

Cardinal Direction: Use an upper case D font. The first letter will be 7 inches and the following letters will be 6 inches.

4G - Minor Intersection Guide Signs

Destination: Use a mixed case D font. Letter sizing is 6 inches for upper case and 4 inches for lower case.

Distance: Typically, distance is not given.

Shields: Typically, shields are not used.

Arrows: Use 6 inch arrows for multiple destinations. Use an 8 inch arrow for a single destination. For multiple destinations; destinations will be separated with a line, destinations requiring forward and left arrows will be placed above destinations requiring right arrows. Left and forward arrows will be placed to the left of the destination, right arrows will be placed to the right of the destination. For single destinations the arrow is always below.

Cardinal Direction: Typically, cardinal directions are not used on minor interchanges.

4H - Distance Signs Located on Interstate Highways

Destination: Use a mixed case E-modified font. Letter sizing is 13.33 inches for uppercase and 10 inches for lower case. For destinations, use the nearest town and nearest control city.

Distance: Use a 13.33 inch E-modified font.

4I - Distance Signs Located on Non-Interstate Highways

Destination: Use a mixed case D font. Letter sizing is 6 inches for upper case and 4 inches for lower case. For destinations, use the nearest towns.

Distance: Use a 6 inch D font.

4J – Control City Signing

Destination: At an interchange on a NHS crossroad, use the nearest control city.
At an interchange on a Non-NHS crossroad use the nearest towns.

Control Cities: I-25: Ft. Collins, Cheyenne, Casper, Sheridan
I-80: Salt Lake City, Evanston, Rock Springs, Cheyenne, Sidney
I-90: Billings, Sheridan, Gillette, Rapid City

5 - Signing Materials

Highway signs are composed of three parts; the substrate, background sheeting, and the sign legend. The substrate gives the sign rigidity and can be made from various materials including steel, aluminum, and wood. Sheeting material covers the substrate and is typically the background color of the sign. The legend of the sign transfers the information of the sign to the motorist.

5A - Substrate

The Wyoming Department of Transportation uses two types of materials for the substrate. These materials are aluminum and plywood.

Sheet Aluminum

Sheet aluminum provides a smooth surface and comes in a variety of precut sizes to match most standard sized signs. Signs designed using sheet aluminum should be designed in increments of 6 inches for both height and width. The maximum size sign designed using sheet aluminum is 8 X 4 feet. The following aluminum thicknesses are to be used in the following instances:

0.040 is used exclusively to overlay existing signs

0.080 is used by the Wyoming Department of Transportation's Sign Shop for fabricated signs.

0.125 is used for Contractor fabricated signs.

Plywood

High Density Overlay (HDO) plywood is the only plywood allowed for permanent signing. Primer is not required between the face of the plywood and sheeting, however all edges must be sealed. HDO plywood is a very rigid material which performs well in high wind areas. This material is used for signs 8 X 4 feet and larger and when sign width exceeds 54 inches. Signs designed using HDO plywood should be designed in increments of 6 inches for both height and width. For all applications ¾ inch HDO plywood is used.

5B - Background Sheeting

There are numerous types of background sheeting available and each has its advantages and disadvantages. It is very important to specify which type of sheeting is to be used. The following sheeting types are used by the Wyoming Department of Transportation:

ASTM Type IV is a multi-layer sheeting, often called prismatic sheeting. Type IV sheeting is required for all signs not requiring fluorescence.

ASTM Type IX is a highly retroreflective sheeting. Type IX sheeting is required for all signs requiring fluorescence. Available fluorescent colors are orange, yellow, and yellow-green.

5C - Sign Legend

Once the background sheeting has been applied to the substrate, the legend can then be applied to the sign face. The Wyoming Department of Transportation allows only the direct applied method. The following sheeting types are used by the Wyoming Department of Transportation:

3M 1178 or approved equal, black non reflective is required for legends requiring the color black.

ASTM Type IV is required for all ground mounted signs with the exception of guide signs.

ASTM Type IX is required for all ground mounted guide signs.

ASTM Type XI is required for all overhead guide signs.

Opaque EC Film may be substituted for ASTM Type IV on ground mounted signs, guide sign are excepted.

5D - Additional Requirements

When signing within the boundaries of **National Forest Service** several requirements must be met. Memorandum of Understanding: 15-MU-11020000-029 requires the following:

- 1) Steel sign posts must be color treated by either powder coating or painting with color conforming to Federal Standard 595 Color FS 20059 (dark brown). Weathering steel posts should not be specified. Break-away assemblies and base plates should not be coated or painted. Square tubular steel sign posts 3 inches or less per side and round tubular steel posts 3 inches O.D. or less are exempt from the dark brown color requirement. The associated anchor system is also exempt.
- 2) Sign backs (plywood and aluminum) are to be treated with 3M Series 1179 Brown EC Film or equivalent. Mounting hardware is exempt from the color requirement. This treatment applies to all new or replacement signs located on highways within the boundaries of National Forests except Interstate 80. This standard also applies to United State Forest Service installed and maintained signs on WYDOT highway Right of Ways.

6 - Sign Supports and Foundations

There are several types of sign supports that may be employed on projects. Supports include timber posts, round tubular steel posts, perforated square tubular steel, and wide flange (WF) steel breakaway supports. All sign supports for primary signs located on the State Highway System must have breakaway features. Sign supports for secondary signs, located outside of the clear zone or protected by barrier should have breakaway features but can be omitted at the Engineers discretion. When selecting a post, timber should always be the first consideration. Upon review from the Engineer, any recommended changes to post type will be reasonably accommodated.

6A - Timber Posts

Timber posts are by far the most commonly utilized support on the Wyoming Highway System. The Wyoming Department of Transportation only allows the use of pressure-treated wood for posts. All timber posts within the clear zone must meet breakaway requirements. Timber posts outside of the clearzone or protected by barrier should meet breakaway requirements, but holes can be omitted at the discretion of the Engineer. To meet breakaway requirements, holes are to be drilled.

Timber Posts Inside of the Clear Zone

Inside of the clear zone timber posts may be used. The maximum size timber post size is 6 X 8 inches and the maximum number of posts is two. The maximum width of a sign on a single post is limited to 5 feet, 14 feet if 2 posts are used. If a 6 X 6 or 6 X 8 inch timber post is used the clear distance between the posts must not be less than 7 feet.

Timber Posts Outside of Clear zone

Outside of the clear zone timber posts may be used. The maximum timber post size is 10 X 10 inches and the maximum number of posts is four. The maximum sign width on a single post is limited to 5 feet.

Figure 6-1 Rectangular Timber Post Selection Inside Clearzone

X = 10 Ft and Below

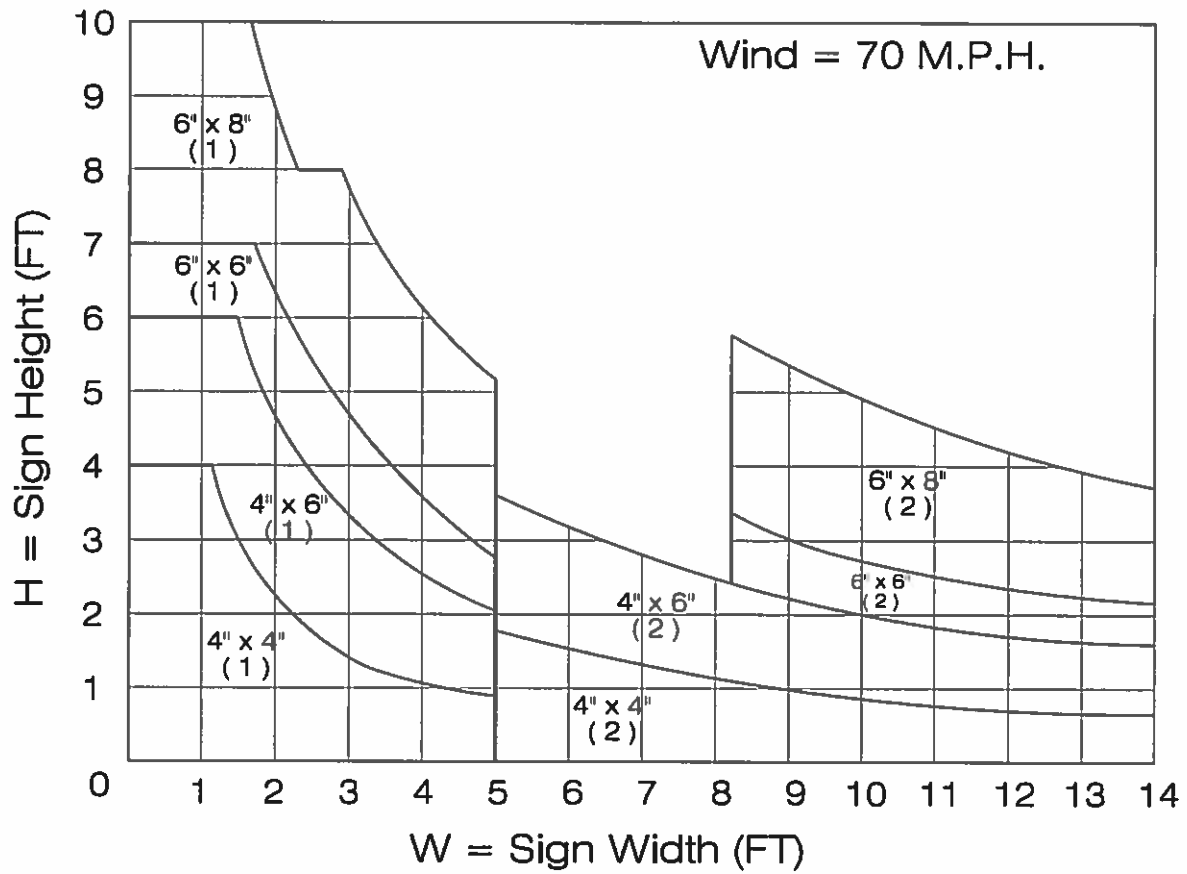

Figure 6-2 Rectangular Timber Post Selection Outside Clearzone

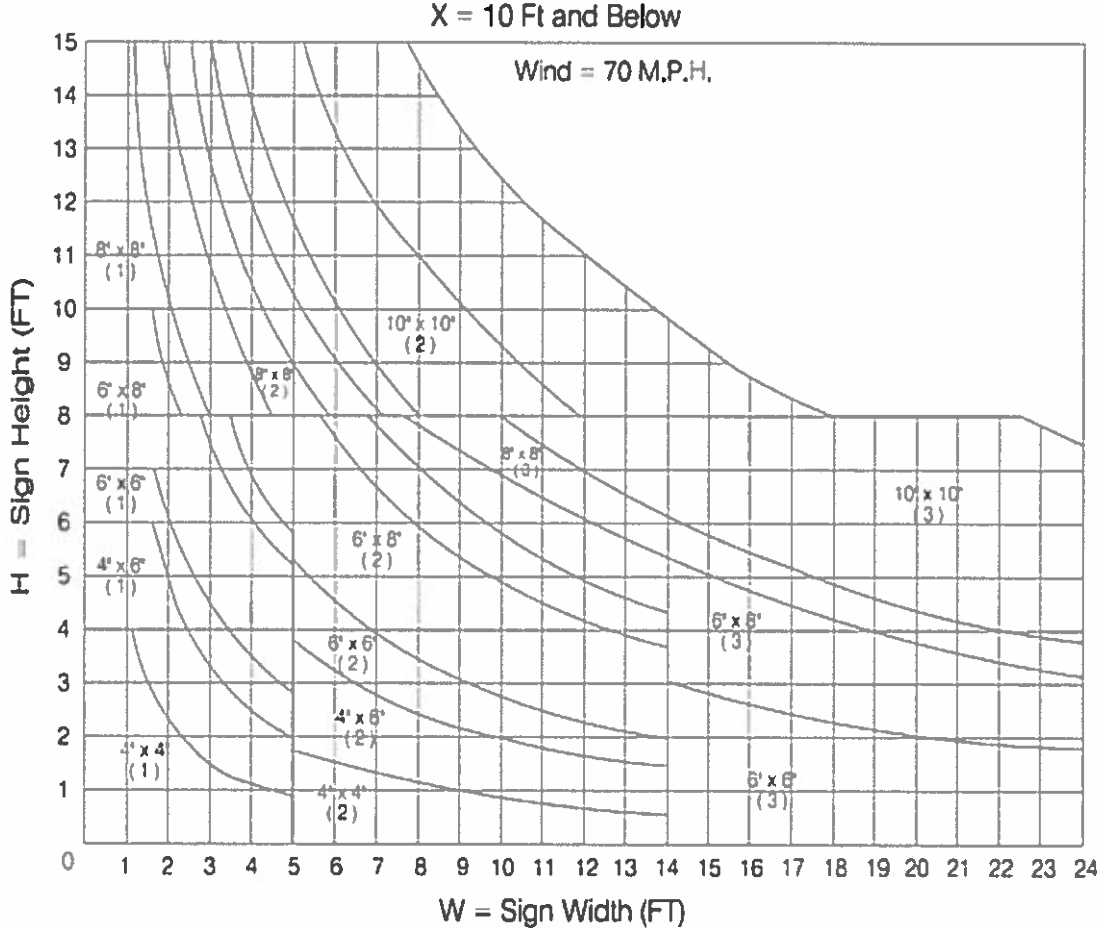

Figure 6-3 Breakaway and Embedment Requirements For Timber Posts

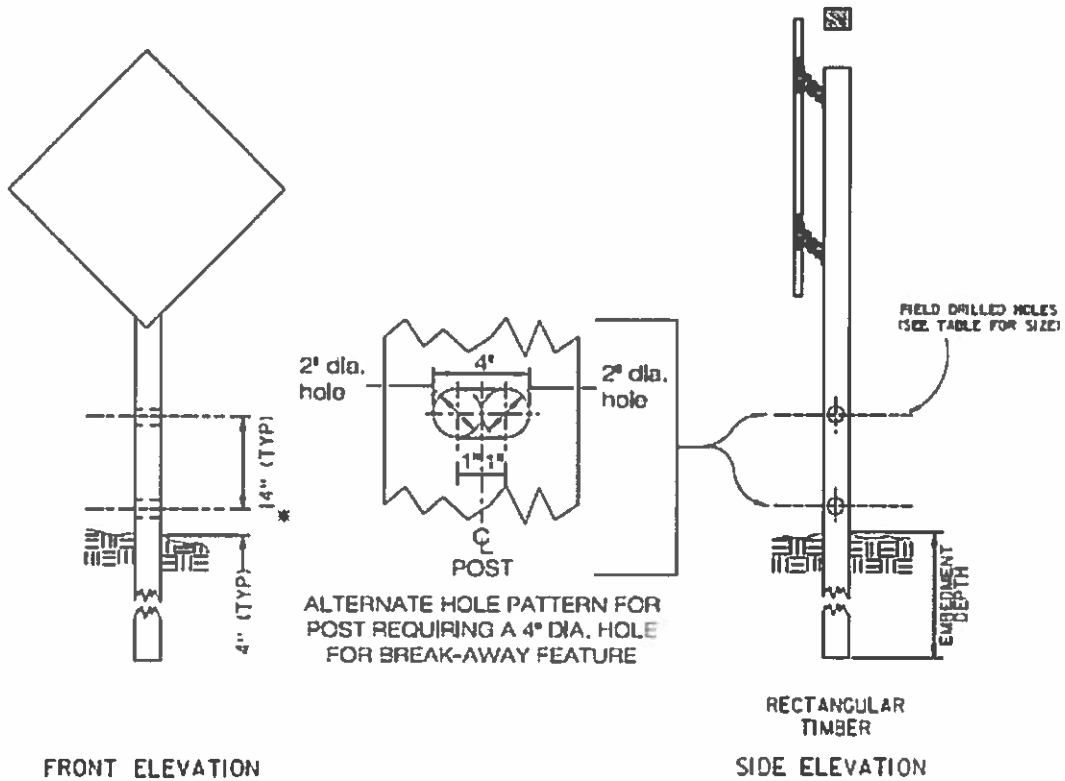

TABLE OF HOLE DIAMETERS						
SURFACED TIMBER POSTS						
POST SIZE (Stated) POST SIZE (Actual)	4"X4" (3.5"X3.5")	4"X6" (3.5"X5.5")	6"X6" (5.5"X5.5")	6"X8" (5.5"X7.5")	8"X8" (7.5"X7.5")	10"X10" (9.5"X9.5")
HOLE DIAMETER	NO HOLE	1/2"Ø	2"Ø	3"Ø	3"Ø	4"Ø
ROUGH DIMENSIONED TIMBER POSTS						
POST SIZE	4"X4"	4"X6"	6"X6"	6"X8"	8"X8"	10"X10"
HOLE DIAMETER	1"Ø	2"Ø	2 1/2"Ø	4"Ø	4"Ø	4"Ø
EMBEDMENT DEPTH	4'	5'	6'	7'	7'	10'

* POST SIZE MEASURED 4" ABOVE GROUND LINE FOR BREAK-AWAY FEATURE.

6B - Round Tubular Posts

Round tubular posts are composed of a 2 ½ inch steel post attached to a ground stub with a triangular slip base casing. These posts are designed to breakaway on impact. Post and assemblies are designed to be reused after being knocked down. Round tubular posts are a good option for small signs in urban areas and in cases where impacts are frequent; an example is the exit gore sign on mainline interstate. The maximum width of a sign on a single post is limited to 5 feet.

Figure 6-4 Round Tubular Breakaway Steel Post Selection Chart

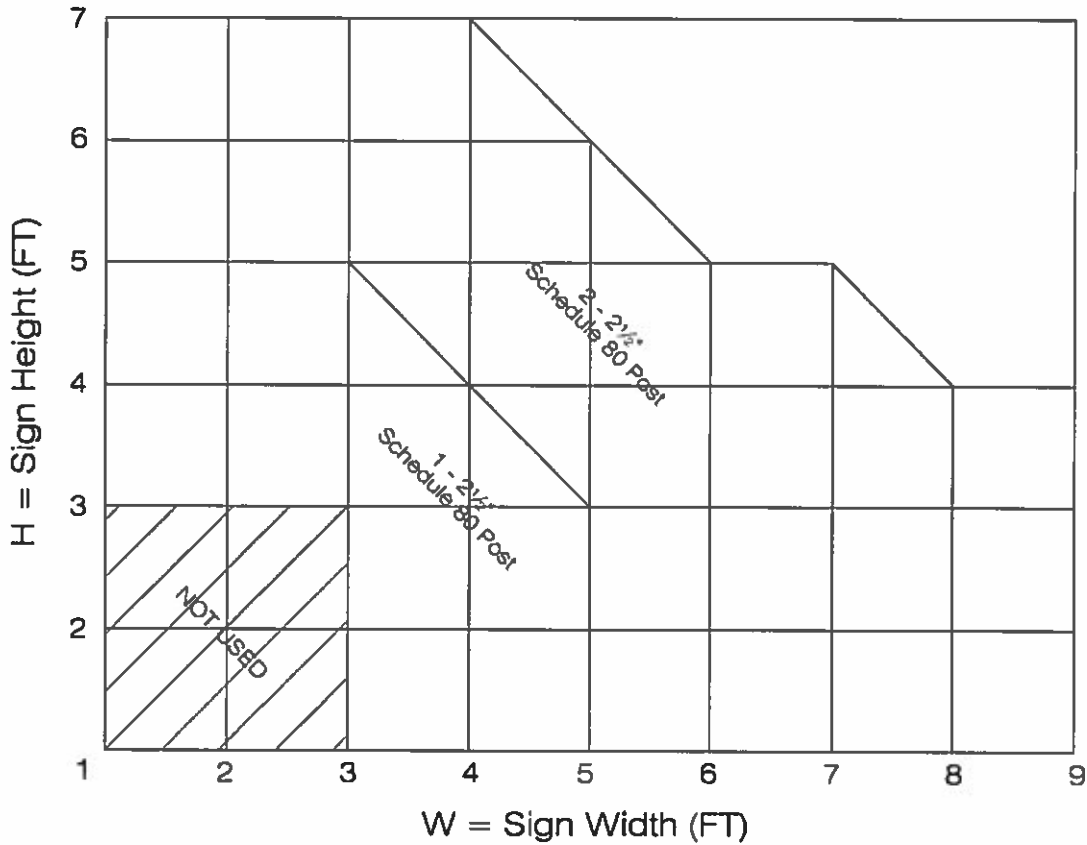

Figure 6-5 Round Tubular Steel Post Detail

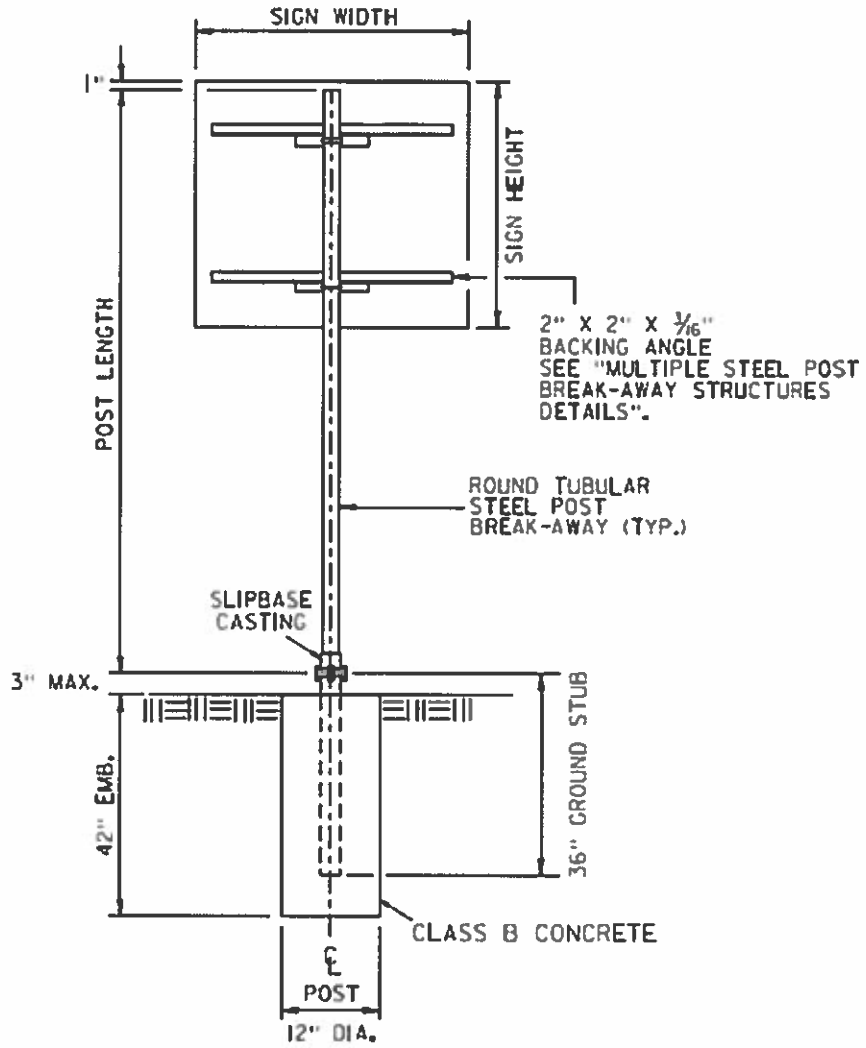
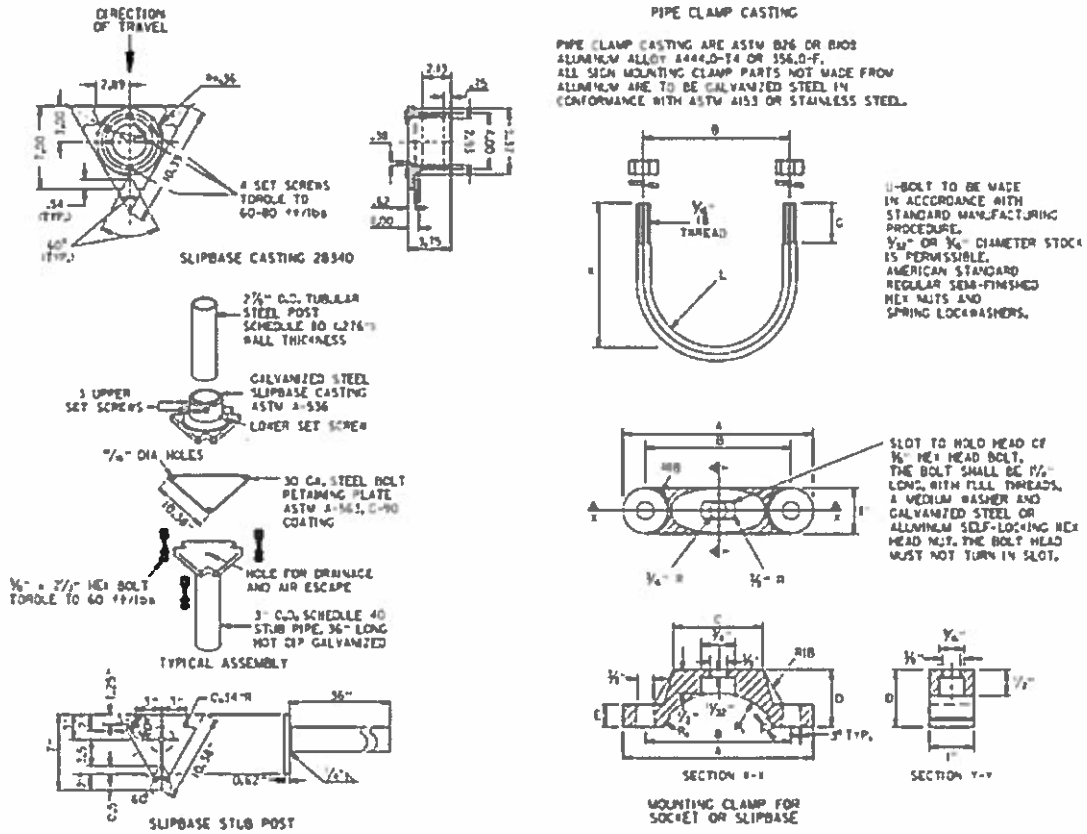

Figure 6-6 Round Tubular Steel Post Connection Detail

DIMENSIONS FOR MOUNTING CLAMP

STANDARD PIPE SIZE	A	B	C	D	E	F	G	L	L	R ₁	R ₂
2 1/2	4 1/2	5 1/2	2	1 1/4	1/2	1/4	1	3 3/8	1 1/2	1 1/2	1 1/4



NOTES:

1. SIGN AND POST INCLUDE THE FOOTING, SLIPBASE AND ALL HARDWARE NECESSARY FOR COMPLETE INSTALLATION.
2. WHEN INSTALLING THE LOWER SET SCREW, INSTALL SIGN POST WITH SIGN ATTACHED INTO THE SLIPBASE CASTING AND ALIGN THE SIGN WITH THE TRAFFIC. THEN WITH THE LOWER SET SCREW REMOVED USE A CENTER PUNCH OR PEN TO MARK THE CENTER OF THE HOLE. THEN REMOVE THE SIGN POST FROM THE CASTING AND DRILL A 1/2" HOLE THROUGH THE SIGN POST. THIS ELIMINATES DAMAGING THE SET SCREW THREADS. REINSTALL THE SIGN POST AND SIGN AND TORQUE THE 4 SET SCREWS TO 60-80 FT-LBS.

6C - Perforated Square Tubular Steel Posts

Perforated square tubular steel posts, commonly referred to as telespar, are composed of a square post that telescopically slips into a ground anchor sleeve. These posts are considered breakaway if they are 2 ½ inches or less in size. The Wyoming Department of Transportation allows post sizes of 2, 2 ¼, and 2 ½ inches to be used. 2 ½ inch is preferred to maintain consistency with field maintenance operations. These posts are ideal for small signs in both urban and rural areas. The maximum sign width on a single post is limited to 4feet. Multiple post installations are only allowed on 2 inch post sizes.

Figure 6-7 Perforated Square Tubular Steel Post Selection Chart

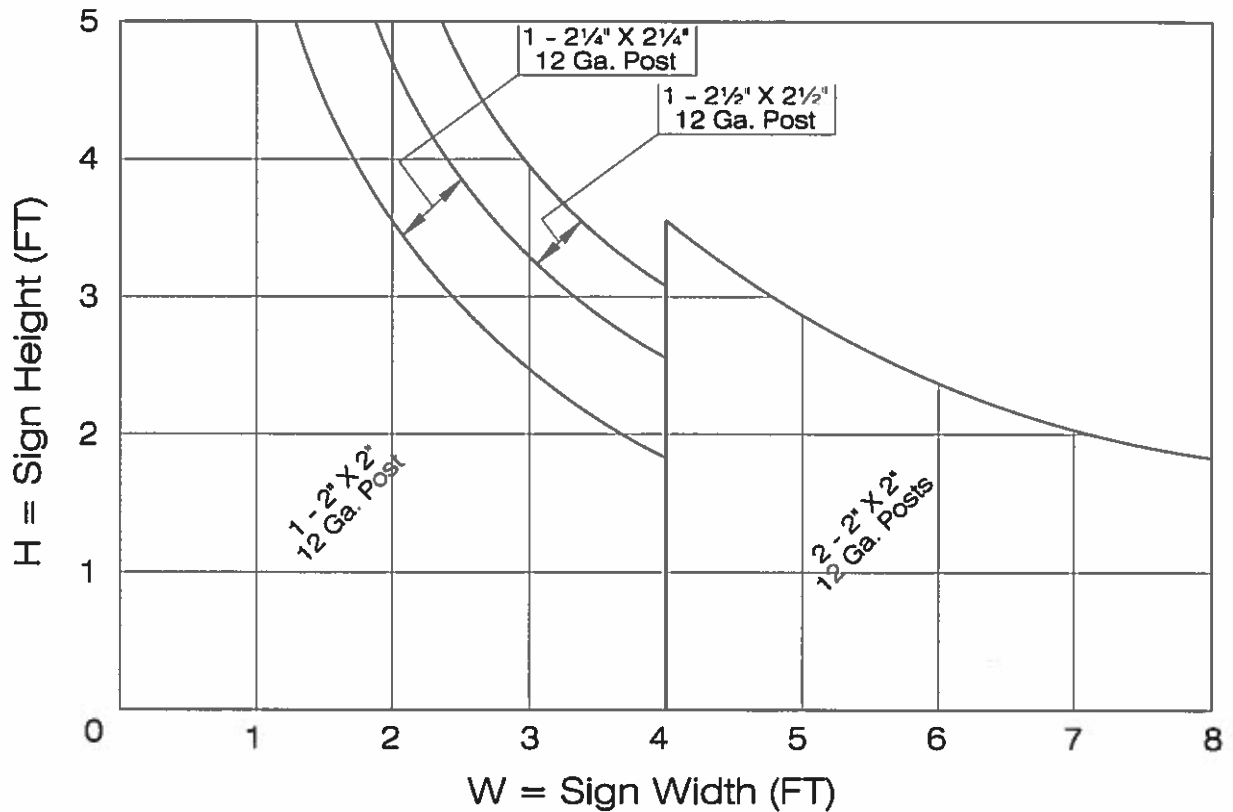

Figure 6-8 Perforated Square Tubular Post Details

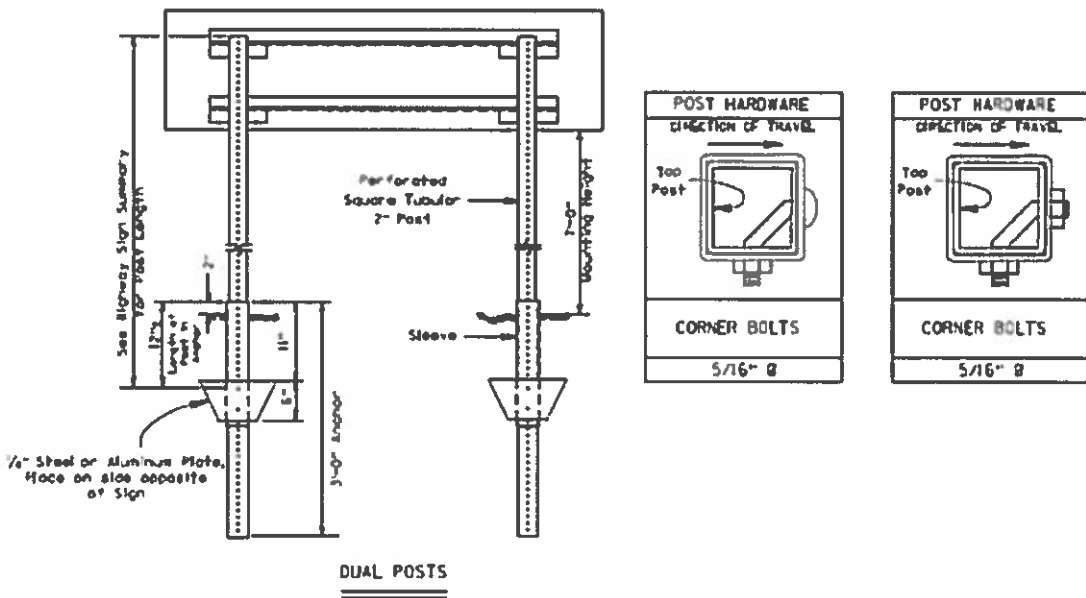
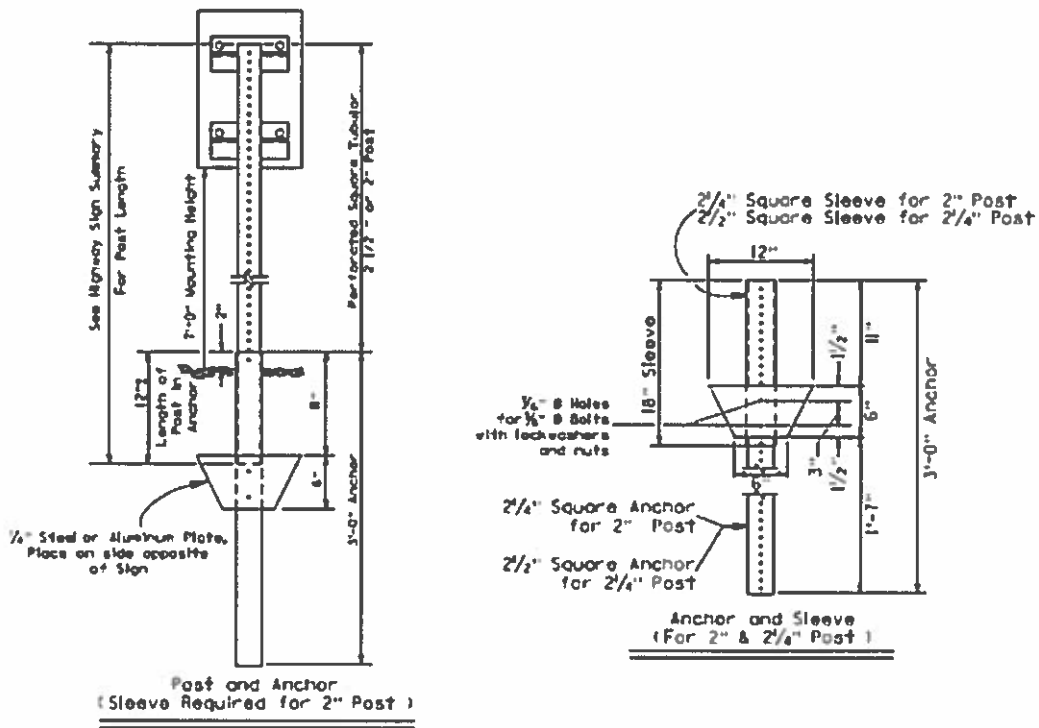

Table 6-1 Perforated Square Tubular Post Member Sized

ASTM A570 Steel, Fy=60 Ksi (min)		
POST SIZE	ANCHOR SIZE	SLEEVE SIZE
2" X 2" X 12 Ga.	2 1/4" X 2 1/4" X 12 Ga.	2 1/2" X 2 1/2" X 12 Ga.
2 1/4" X 2 1/4" X 12 Ga.	2 1/2" X 2 1/2" X 12 Ga.	3" X 3" X 3/16"
2 1/2" X 2 1/2" X 12 Ga.	3" X 3" X 3/16"	-

12 Ga = 0.105"

NOTE:

- 1) Fabricate tubular steel sign posts from steel sheets conforming to ASTM A 570, Grade 50, or ASTM A 653, Structural Quality, Grade 50. Galvanize posts in accordance with ASTM A 653, G90 or G140. Bright Zinc plate or Galvanize all connecting hardware.
- 2) Provide certification from manufacturer of posts that materials furnished have chemistries, mechanical properties and geometries consistent with materials used in the latest accepted breakaway testing, and that supports made from the materials will meet FHWA breakaway requirements.

6D - I-Beam Breakaway Steel Posts

I-Beam Steel Posts are composed of steel I-beams founded on Drilled Shaft Foundations. A multi-directional slip plate allows the post to breakaway on impact. In most cases, this is the only option for large signs in the clearzone. Outside of the clearzone, this type of support should not be used and engineering judgment should be used when selecting a suitable alternative.

For dimension X see section on determination of post length.

Table 6-2 Breakaway Steel Post Selection (X = 10')

POST SELECTION TABLE - TWO POSTS												
X = 10'												
Width "W" (Feet)	Height "H" (Feet)											
	4	5	6	7	8	9	10	11	12	13	14	15
6	W6x15	W6x15	W6x15	W6x15	W6x15	W6x15	W6x15	W6x15	-	-	-	-
7	W6x15	W6x15	W6x15	W6x15	W6x15	W6x15	W6x15	-	-	-	-	-
8	W6x15	W6x15	W6x15	W6x15	W6x15	W6x15	-	-	-	-	-	-
9	W6x15	W6x15	W6x15	W6x15	W6x15	W6x15	-	-	-	-	-	-
10	W6x15	W6x15	W6x15	W6x15	W6x15	W8x21	W8x21	W8x21	W10x26	W10x26	W10x26	W10x26
11	W6x15	W6x15	W6x15	W6x15	W8x21	W8x21	W8x21	W10x26	W10x26	W10x26	W10x26	W14x30
12	W6x15	W6x15	W6x15	W8x21	W8x21	W8x21	W8x21	W10x26	W10x26	W10x26	W10x26	W14x30
13	W6x15	W6x15	W6x15	W8x21	W8x21	W8x21	W8x21	W10x26	W10x26	W14x30	W14x30	W14x30
14	W6x15	W6x15	W6x15	W8x21	W8x21	W8x21	W10x26	W10x26	W10x26	W14x30	W14x30	W18x40
15	W6x15	W6x15	W8x21	W8x21	W8x21	W8x21	W10x26	W10x26	W14x30	W14x30	W18x40	W21x44
16	W6x15	W6x15	W8x21	W8x21	W8x21	W10x26	W10x26	W10x26	W14x30	W18x40	W21x44	-
17	W6x15	W6x15	W8x21	W8x21	W8x21	W10x26	W10x26	W10x26	W14x30	W18x40	-	-
18	W6x15	W8x21	W8x21	W8x21	W10x26	W10x26	W10x26	W14x30	W18x40	-	-	-
19	W6x15	W8x21	W8x21	W8x21	W10x26	W10x26	W14x30	W18x40	W21x44	-	-	-
20	W6x15	W8x21	W8x21	W8x21	W10x26	W10x26	W14x30	W18x40	-	-	-	-
21	W6x15	W8x21	W8x21	W10x26	W10x26	W10x26	W18x40	W21x44	-	-	-	-

POST SELECTION TABLE - THREE POSTS												
X = 10'												
Width "W" (Feet)	Height "H" (Feet)											
	4	5	6	7	8	9	10	11	12	13	14	15
19	W6x15	W6x15	W8x21	W8x21	W8x21	W10x26	W10x26	W10x26	W14x30	W18x40	W21x44	-
20	W6x15	W6x15	W8x21	W8x21	W8x21	W10x26	W10x26	W10x26	W14x30	W18x40	W21x44	-
21	W6x15	W6x15	W8x21	W8x21	W8x21	W10x26	W10x26	W10x26	W14x30	W18x40	W21x44	-
22	W6x15	W6x15	W8x21	W8x21	W8x21	W8x21	W10x26	W10x26	W14x30	W14x30	W18x40	W21x44
23	W6x15	W6x15	W8x21	W8x21	W8x21	W10x26	W10x26	W10x26	W14x30	W18x40	W21x44	-
24	W6x15	W6x15	W8x21	W8x21	W8x21	W10x26	W10x26	W10x26	W14x30	W18x40	-	-
25	W6x15	W6x15	W8x21	W8x21	W8x21	W10x26	W10x26	W10x26	W18x40	W21x44	-	-
26	W6x15	W8x21	W8x21	W8x21	W10x26	W10x26	W10x26	W14x30	W18x40	-	-	-
27	W6x15	W8x21	W8x21	W8x21	W10x26	W10x26	W10x26	W14x30	W21x44	-	-	-
28	W6x15	W8x21	W8x21	W8x21	W10x26	W10x26	W10x26	W18x40	W21x44	-	-	-
29	W6x15	W8x21	W8x21	W8x21	W10x26	W10x26	W14x30	W18x40	-	-	-	-
30	W6x15	W8x21	W8x21	W8x21	W10x26	W10x26	W14x30	W21x44	-	-	-	-

NOTES:

1. Shaded cells indicate a center to center post spacing of 7 ft - 9 in, which deviates from 0.6W for two posts and 0.35W for three posts.
2. Always use the dimension "X" for the tallest post of the roadside sign.
3. Refer to "General Notes of Standard Details" for additional information.
4. The following are requirements of the Standard Specifications For Structural Supports For Highway Signs, Luminaires, and Traffic Signals (Fifth Edition, 2009):
 "A single post, spaced with a clear distance of 7 ft or more from another post, shall have a mass no greater than 44 lb/ft. The total mass below the hinge, but above the shear plate of the breakaway base, shall not exceed 600 lb. For two posts spaced with less than 7 ft clearance, each post shall have a mass less than 17 lb/ft."

Table 6-2 Breakaway Steel Post Selection (X = 12')

POST SELECTION TABLE - TWO POSTS												
X = 12'												
Width "W" (Feet)	Height "H" (Feet)											
	4	5	6	7	8	9	10	11	12	13	14	15
6	W6x15	W6x15	W6x15	W6x15	W6x15	W6x15	-	-	-	-	-	-
7	W6x15	W6x15	W6x15	W6x15	W6x15	-	-	-	-	-	-	-
8	W6x15	W6x15	W6x15	W6x15	W6x15	-	-	-	-	-	-	-
9	W6x15	W6x15	W6x15	W6x15	-	-	-	-	-	-	-	-
10	W6x15	W6x15	W6x15	W8x21	W8x21	W8x21	W8x21	W10x26	W10x26	W10x26	W14x30	W14x30
11	W6x15	W6x15	W6x15	W8x21	W8x21	W8x21	W8x21	W10x26	W10x26	W10x26	W14x30	W14x30
12	W6x15	W6x15	W8x21	W8x21	W8x21	W8x21	W10x26	W10x26	W10x26	W14x30	W14x30	W18x40
13	W6x15	W6x15	W8x21	W8x21	W8x21	W10x26	W10x26	W10x26	W14x30	W14x30	W18x40	W21x44
14	W6x15	W8x21	W8x21	W8x21	W10x26	W10x26	W10x26	W14x30	W14x30	W14x30	W18x40	-
15	W6x15	W8x21	W8x21	W8x21	W10x26	W10x26	W10x26	W14x30	W14x30	W14x30	W18x40	-
16	W6x15	W8x21	W8x21	W10x26	W10x26	W10x26	W14x30	W14x30	W18x40	W21x44	-	-
17	W6x15	W8x21	W8x21	W10x26	W10x26	W14x30	W14x30	W18x40	W21x44	-	-	-
18	W8x21	W8x21	W8x21	W10x26	W10x26	W14x30	W14x30	W18x40	-	-	-	-
19	W8x21	W8x21	W8x21	W10x26	W10x26	W14x30	W18x40	W21x44	-	-	-	-
20	W8x21	W8x21	W10x26	W10x26	W14x30	W14x30	W18x40	-	-	-	-	-
21	W8x21	W8x21	W10x26	W10x26	W14x30	W18x40	W21x44	-	-	-	-	-

POST SELECTION TABLE - THREE POSTS												
X = 12'												
Width "W" (Feet)	Height "H" (Feet)											
	4	5	6	7	8	9	10	11	12	13	14	15
19	W6x15	W8x21	W8x21	W8x21	W10x26	W10x26	W14x30	W14x30	W18x40	W21x44	-	-
20	W6x15	W8x21	W8x21	W8x21	W10x26	W10x26	W14x30	W14x30	W18x40	W21x44	-	-
21	W6x15	W8x21	W8x21	W8x21	W10x26	W10x26	W14x30	W14x30	W18x40	W21x44	-	-
22	W6x15	W8x21	W8x21	W8x21	W10x26	W10x26	W14x30	W14x30	W14x30	W18x40	-	-
23	W6x15	W8x21	W8x21	W8x21	W10x26	W10x26	W14x30	W14x30	W18x40	W21x44	-	-
24	W6x15	W8x21	W8x21	W10x26	W10x26	W10x26	W14x30	W14x30	W18x40	-	-	-
25	W6x15	W8x21	W8x21	W10x26	W10x26	W10x26	W14x30	W14x30	W18x40	W21x44	-	-
26	W6x15	W8x21	W8x21	W10x26	W10x26	W14x30	W14x30	W18x40	-	-	-	-
27	W8x21	W8x21	W8x21	W10x26	W10x26	W14x30	W14x30	W21x44	-	-	-	-
28	W8x21	W8x21	W8x21	W10x26	W10x26	W14x30	W18x40	W21x44	-	-	-	-
29	W8x21	W8x21	W10x26	W10x26	W10x26	W14x30	W18x40	-	-	-	-	-
30	W8x21	W8x21	W10x26	W10x26	W14x30	W14x30	W18x40	-	-	-	-	-

NOTES:

1. Shaded cells indicate a center to center post spacing of 7 ft - 9 in, which deviates from 0.6W for two posts and 0.35W for three posts.
2. Always use the dimension "X" for the tallest post of the roadside sign.
3. Refer to "General Notes of Standard Details" for additional information.
4. The following are requirements of the Standard Specifications For Structural Supports For Highway Signs, Luminaires, and Traffic Signals (Fifth Edition, 2009):
 "A single post, spaced with a clear distance of 7 ft or more from another post, shall have a mass no greater than 44 lb/ft. The total mass below the hinge, but above the shear plate of the breakaway base, shall not exceed 600 lb. For two posts spaced with less than 7 ft clearance, each post shall have a mass less than 17 lb/ft."

Table 6-3 Breakaway Steel Selection (X = 14')

POST SELECTION TABLE - TWO POSTS												
X = 14'												
Width "W"	Height "H" (Feet)											
(Feet)	4	5	6	7	8	9	10	11	12	13	14	15
6	W6x15	W6x15	W6x15	W6x15	-	-	-	-	-	-	-	-
7	W6x15	W6x15	W6x15	-	-	-	-	-	-	-	-	-
8	W6x15	W6x15	W6x15	-	-	-	-	-	-	-	-	-
9	W6x15	W6x15	-	-	-	-	-	-	-	-	-	-
10	W6x15	W8x21	W8x21	W8x21	W8x21	W10x26	W10x26	W10x26	W14x30	W14x30	W18x40	W18x40
11	W6x15	W8x21	W8x21	W8x21	W10x26	W10x26	W10x26	W14x30	W14x30	W18x40	W18x40	-
12	W6x15	W8x21	W8x21	W8x21	W10x26	W10x26	W14x30	W14x30	W14x30	W18x40	W18x40	-
13	W8x21	W8x21	W8x21	W10x26	W10x26	W10x26	W14x30	W14x30	W14x30	W18x40	W18x40	-
14	W8x21	W8x21	W8x21	W10x26	W10x26	W14x30	W14x30	W18x40	W18x40	-	-	-
15	W8x21	W8x21	W10x26	W10x26	W10x26	W14x30	W14x30	W18x40	W18x40	-	-	-
16	W8x21	W8x21	W10x26	W10x26	W14x30	W14x30	W18x40	W18x40	-	-	-	-
17	W8x21	W8x21	W10x26	W10x26	W14x30	W14x30	W18x40	-	-	-	-	-
18	W8x21	W10x26	W10x26	W14x30	W14x30	W18x40	W18x40	-	-	-	-	-
19	W8x21	W10x26	W10x26	W14x30	W14x30	W18x40	-	-	-	-	-	-
20	W8x21	W10x26	W10x26	W14x30	W18x40	W18x40	-	-	-	-	-	-
21	W8x21	W10x26	W10x26	W14x30	W18x40	-	-	-	-	-	-	-

POST SELECTION TABLE - THREE POSTS												
X = 14'												
Width "W"	Height "H" (Feet)											
(Feet)	4	5	6	7	8	9	10	11	12	13	14	15
19	W8x21	W8x21	W10x26	W10x26	W14x30	W14x30	W18x40	W18x40	-	-	-	-
20	W8x21	W8x21	W10x26	W10x26	W14x30	W14x30	W18x40	W18x40	-	-	-	-
21	W8x21	W8x21	W10x26	W10x26	W14x30	W14x30	W18x40	W18x40	-	-	-	-
22	W8x21	W8x21	W10x26	W10x26	W14x30	W14x30	W14x30	W18x40	-	-	-	-
23	W8x21	W8x21	W10x26	W10x26	W14x30	W14x30	W14x30	W18x40	W18x40	-	-	-
24	W8x21	W8x21	W10x26	W10x26	W14x30	W14x30	W18x40	-	-	-	-	-
25	W8x21	W8x21	W10x26	W10x26	W14x30	W14x30	W18x40	-	-	-	-	-
26	W8x21	W8x21	W10x26	W10x26	W14x30	W18x40	W18x40	-	-	-	-	-
27	W8x21	W10x26	W10x26	W14x30	W14x30	W18x40	-	-	-	-	-	-
28	W8x21	W10x26	W10x26	W14x30	W14x30	W18x40	-	-	-	-	-	-
29	W8x21	W10x26	W10x26	W14x30	W14x30	W18x40	-	-	-	-	-	-
30	W8x21	W10x26	W10x26	W14x30	W18x40	W18x40	-	-	-	-	-	-

NOTES:

1. Shaded cells indicate a center to center post spacing of 7 ft - 9 in, which deviates from 0.6W for two posts and 0.35W for three posts.
2. Always use the dimension "X" for the tallest post of the roadside sign.
3. Refer to "General Notes of Standard Details" for additional information.
4. The following are requirements of the Standard Specifications For Structural Supports For Highway Signs, Luminaires, and Traffic Signals (Fifth Edition, 2009):
 "A single post, spaced with a clear distance of 7 ft or more from another post, shall have a mass no greater than 44 lb/ft. The total mass below the hinge, but above the shear plate of the breakaway base, shall not exceed 600 lb. For two posts spaced with less than 7 ft clearance, each post shall have a mass less than 17 lb/ft."

Table 6-4 Drilled Shaft Data

Post Size	DRILLED SHAFT DATA		
	Drilled Shaft Diameter	Drilled Shaft Embedment	Size & Length of Vertical Reinforcement
W6 x 15	30"	6'	No. 8 x 5'-10"
W8 x 21	30"	7'	No. 8 x 6'-10"
W10 x 26	30"	8'	No. 8 x 7'-10"
W14 x 30	36"	9'	No. 9 x 8'-10"
W18 x 40	42"	8'	No. 9 x 7'-10"
W21 x44	42"	9'	No. 9 x 8'-10"

GENERAL NOTES: WYDOT'S Standard Specifications for Road and Bridge Construction, 2010 Edition.

STRUCTURAL STEEL: Use steel conforming to ASTM A 709 Grade 50 for Sky Posts.

BEARING STEEL: Furnish one 4'-6" long square each of No. 8 or No. 9 bar and No. 3 spiral. Provide certification that the fasteners are from the same heat as the reinforcing furnished for the contract.

CONCRETE: Use class B concrete in the drilled shafts.

FIELD MEASUREMENTS: The engineer will provide total lengths in 1' increments and forward a copy of this information to the State Traffic Engineer prior to fabrication.

SHOP DRAWINGS: Furnish shop drawings of the sign posts to the State Traffic Engineer in accordance with Subsection 105.2.2, Shop Drawings. Include the bracket type and bracket section number.

ANCHOR INSTALLATION: Test concrete to place the tops of the anchors for each post at the same elevation as the requirement of installing the post shall be accomplished without exceeding the maximum number of shoves allowed per Sheet Nos. 2 and 4.

ANCHOR TEMPLATES: For the installation of anchors, use templates made from steel plates or from a flat piece of wood that has been stiffened by the attachment of additional right angles to prevent warping and misalignment. Do not use templates having any amount of warping or misalignment.

BREAKAWAY SYSTEMS: For the bracket, anchor, coupling and sign supports, use the "Break-Safe Breakaway System for Ground Mounted Sign Supports" manufactured by Transpo Industries, Inc. of New Rochelle, NY. Provide certification from Transpo Industries, Inc. indicating the above hardware furnished has assembly the same chemistry, mechanical properties, and geometry as was used in the latest approved breaking testing and it meets the FHWA breaking requirements. Also provide certification for the hardware furnished that it meets the same chemistry, mechanical properties, and geometry as was used in the latest approved breaking testing and it meets the FHWA breaking requirements. Also provide certification for the hardware furnished that it meets the same chemistry, mechanical properties, and geometry as was used in the latest approved breaking testing and it meets the FHWA breaking requirements.

BREAKEAWAY SYSTEM INSTALLATION: During installation of breakaway coupling into center and during tightening of second cast into coupling, use the following procedure: do not place force around the necked down portion of the coupling.

BRACKET SWAYS: Supply minimum bracket sways to account for possible variations in post height for a given post size, and to allow for possible post life to use a single anchor bearing for all post numbers.

TOPPING FASTENERS: Tension fasteners as indicated on Sheet No. 3 and No. 4. Sways are defined as the height of the ends when the pins of the joint are in the center and may be obtained by a few layers of a jacket which encircle the full height of a sign using an ordinary stud anchor.

ERECTOR: Erect each sign post individually. Attach the sign panel after the sign posts are in place. Do not erect the sign posts with the sign panel attached to the posts.

FINISHED GROUND SURFACE: Work necessary to finish the ground surface adjacent to the drilled shafts as shown in the contract is incidental to the respective drilled shaft foundation contract pay item.

REVISIONS

Revised for WYDOT's 2013 Standard Specifications.	24-Jun-13
Revised from class B to class C concrete.	31-Jul-10
Revised for the post and offset steel sizes and standard fabrication.	28-Oct-09
Revised bracket drawings to be shown from edge of sign.	08-Apr-11
Updated based on breakaway system manufacturer for single bracket to include the sign panel.	11-Nov-13
For WYDOT's 2013 Standard Specifications.	

WYOMING DEPARTMENT OF TRANSPORTATION

MULTI-DIRECTIONAL BREAKAWAY ROADSIDE SIGNS WITH MULTIPLE STEEL POSTS
(General Details)

Date: 14-Apr-17 Sheet 1 of 5

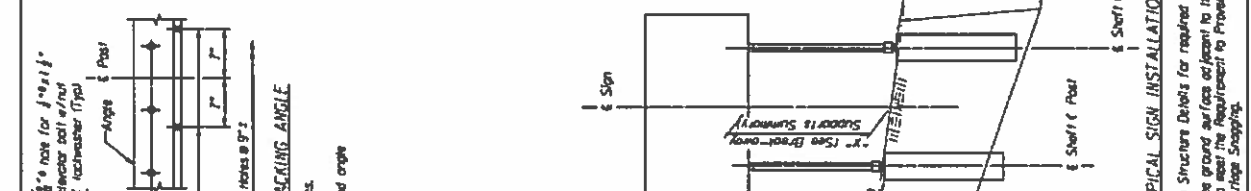

Notes:

- 1) See Sign Structure Details for required post spacing.
- 2) Finish the ground surface adjacent to the drilled shafts to meet the Requirement to Prevent Vehicle Undercarriage Strapping.



Notes:

- 1) Inlet drilled shaft and finish ground surfaces so no portion of the foundation or fractured coupling projects more than 4 inches above a 5-foot long chord connecting a point on the ground surface on one side of the foundation to a point on the ground surface on the other side.



Notes:

- 1) The other brackets to post are not shown.
- 2) 30% ± 3% O.S. shown.
- 3) 42% ± 5% O.S. shown.



Notes:

- 1) See Sign Summary for size of backing and cup angles.
- 2) See Sign Structure Details for cup angle spacing.
- 3) All backing angles, cup angles and bolts for panel and angle assembly are furnished by the Sign Panel Fabricator.



Notes:

- 1) 1 1/2" Hole Checks (or sign assembly erection).
- 2) Ensure post ends have a right fit with at least one point of contact and no gap at any point. Remove all concealing run and bolts from post ends.
- 3) Place bracket splices as required between anchor and post.



Notes:

- 1) The engineer will provide post lengths in 1' increments and forward a copy of this information to the State Traffic Engineer prior to fabrication.

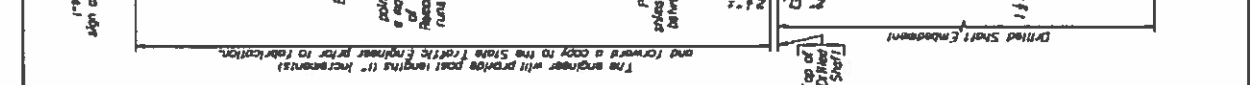

Notes:

- 1) 1 1/2" Hole Checks (or sign assembly erection).
- 2) Ensure post ends have a right fit with at least one point of contact and no gap at any point. Remove all concealing run and bolts from post ends.
- 3) Place bracket splices as required between anchor and post.

REVISED	DATE	BY
X	X	X

ITEM	DESCRIPTION	QTY. PER POST	PART NO.
1	BRACKET	2	SB0425
2a	BRACKET HARDWARE ASSEMBLY, TYPE B525	4	
2b	3" x 2 1/2" Hex Head, ASTM A 325, Gen. ASTM A 153	4	
2c	3" x 2 1/2" Hex Head, ASTM A 325, Gen. ASTM A 153	4	
2d	3" x 1 1/2" Hex Head, ASTM A 325, Gen. ASTM A 153	4	
2e	3" x 1 1/2" Hex Head, ASTM A 325, Gen. ASTM A 153	4	
2f	3" ANSIB B-21-1, Gen. ASTM A 153	16	
2g	3" Hex Head, ASTM A 563 Gr. D1, Gen. ASTM A 153	12	
3	COUPLER C BRACKET ASSEMBLY, TYPE B	1	SB-CBRP
3a	1" ASTM A 449, Gen. ASTM A 151/18 695	4	
3b	1" LP, A53 63760, Gen. ASTM A 153, Proprietary Coat	4	
3c	1" Hex Head, 14 Gauge, Gen. Steel Sheet	2	
3d	1" Hex Head, 18 Gauge, Gen. Steel Sheet	2	
4	WEDGE PLATE	1	SB-WPE
4a	WEDGE ASSEMBLY, TYPE B525	4	
4b	WEDGE HARDWARE ASSEMBLY, TYPE B	4	
4c	3" x 2 1/2" Hex Head, ASTM A 325, Gen. ASTM A 153	8	
4d	3" ANSIB B-21-1, Gen. ASTM A 153	8	
4e	3" Hex Head, ASTM A 563 Gr. D1, Gen. ASTM A 153	8	
4f	Anchor Assembly, Type B	1	SB-ANPK
4g	1" SSM S.S. FERRULE, A517095 Rod, A517028 Con	4	
4h	Bracket Shoe 4x8	1	
4i	Bracket Shoe 5 1/2" x 7" 12 Gauge (1.062" thick), Aluminum Sheet	4	
4j	Bracket Shoe 5 1/2" x 7" 14 Gauge (1.064" thick), Aluminum Sheet	4	
4k	Bracket Shoe 2 1/2" x 7" 22 Gauge (1.025" thick), Aluminum Sheet	2	
4l	Half Bracket Shoe 2 1/2" x 7" 12 Gauge (1.062" thick), Aluminum Sheet	1	
4m	Half Bracket Shoe 2 1/2" x 7" 14 Gauge (1.064" thick), Aluminum Sheet	2	
4n	Half Bracket Shoe 2 1/2" x 7" 22 Gauge (1.025" thick), Aluminum Sheet	2	
4o	Cap Screw 3" x 1 1/8", Hex Head, ASTM A 307, Gen. ASTM A 153	4	

*** Ensure bracket ribs and 1/2" long cap screws (figure supplied with parts).

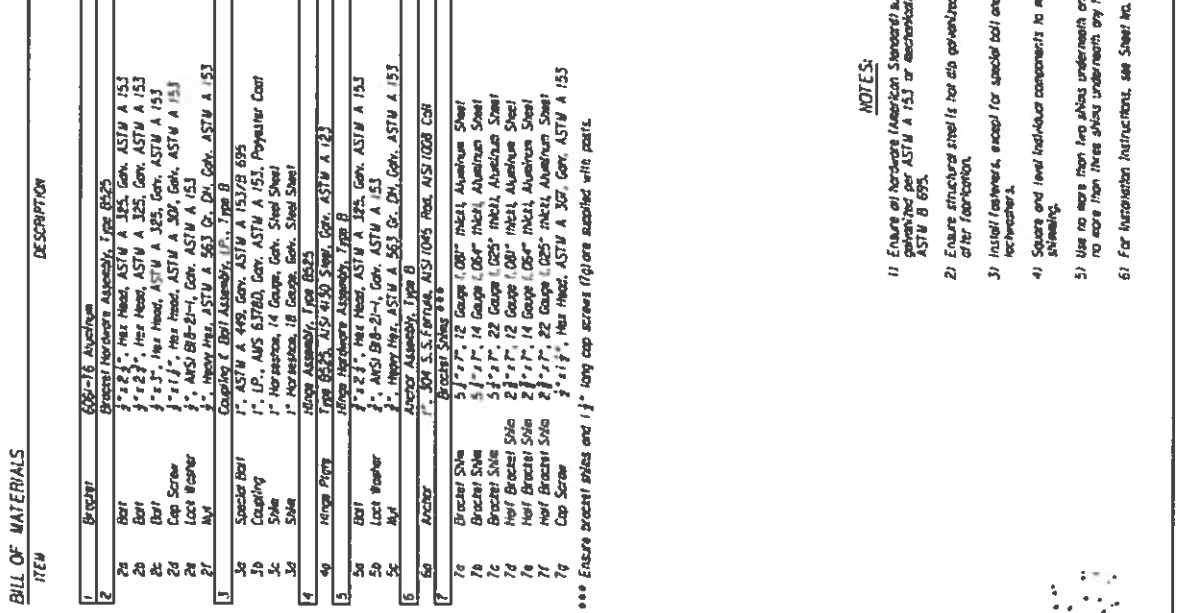

REVISED

Reviewed for WYDOT's 2011 Standard Specifications. Updated for new information from breakaway system manufacturers and new post types. Updated based on breakaway system manufacturer for single bracket injection. It will also be revised for WYDOT's 2015 Standard Specifications.

24-Apr-09
26-Oct-09
13-Mar-15

WYOMING DEPARTMENT OF TRANSPORTATION
MULTI-DIRECTIONAL
BREAKAWAY ROADSIDE SIGNS
WITH MULTIPLE STEEL POSTS
(Breakaway System Details for
6" and 8" Wf Sign Posts)

Date: 14-Apr-17 Sheet 2 of 5

- NOTES:**
- 1) Ensure all hardware (American Standard) supplied is hot dip galvanized per ASTM A 153 or mechanically galvanized per ASTM B 695.
 - 2) Ensure structural steel is hot dip galvanized per ASTM A 123 after fabrication.
 - 3) Install fasteners, except for special bolt and coupling, with lockwasher.
 - 4) Square and level end-hour components to minimize need for shimming.
 - 5) Use no more than two shims underneath any one coupling and no more than three shims underneath any two couplings.
 - 6) For fabrication instructions, see Sheet No. 1.

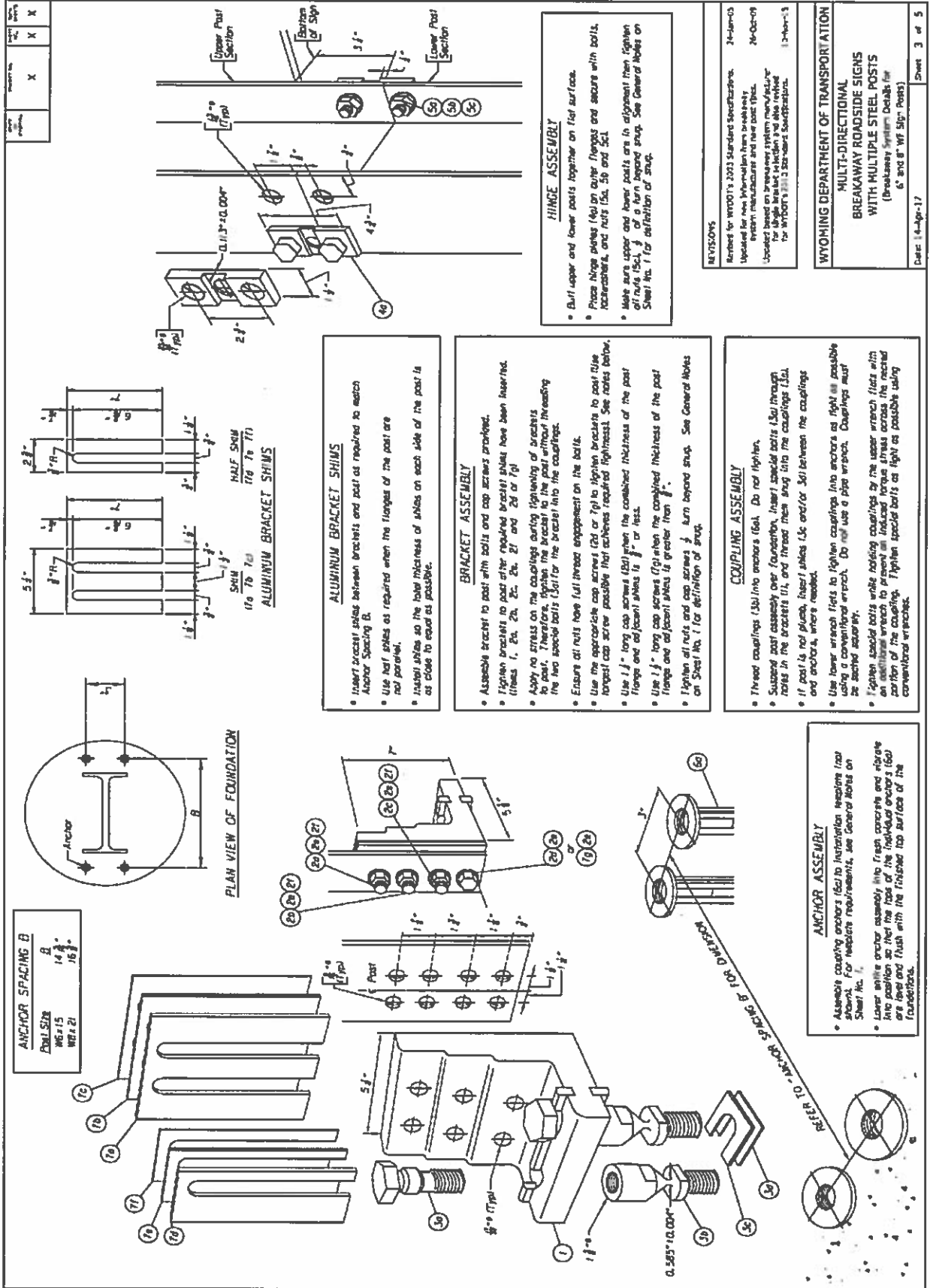

REVISION NO.	X	DATE	
BY			

ITEM NO.	DESCRIPTION	QTY.	PER POST	PART NO.
1	Bracket	2		SBW550
2a	Bracket Hardware Assembly, Type BB50			
2b	3"x2 1/2" Hex Head, ASTM A 325, Gen. ASTM A 153	4		
2c	3"x3 1/2" Hex Head, ASTM A 325, Gen. ASTM A 153	4		
2d	3"x1 1/2" Hex Head, ASTM A 325, Gen. ASTM A 153	4		
2e	3"x1 1/4" Hex Head, ASTM A 307, Gen. ASTM A 153	4		
2f	3"x1 1/4" Hex Head, ASTM A 325, Gen. ASTM A 153	16		
2g	Heavy Hex, ASTM A 563, Cr. Dh. Gen. ASTM A 153	12		
3	Coasting E Bolt Assembly, Type B	1		SB-CBP
4	1" ASTM A 499, Gen. ASTM A 153/B 699	4		
5	1" LP, AMS 63760, Gen. ASTM A 153, Polyester Coat	4		
6	1" Hex Heads, 1/4" Gauge, Gen. Steel Sheet	2		
7	1" Hex Heads, 1/8" Gauge, Gen. Steel Sheet	2		
8	1" Hex Heads, 1/8" Gauge, Gen. Steel Sheet	2		
9	Hinge Pin	1		SB-H82
10	Hinge Hardware Assembly, Type B	1		SB-H82
11	3"x2 1/2" Hex Head, ASTM A 325, Gen. ASTM A 153	8		
12	3"x3 1/2" Hex Head, ASTM A 325, Gen. ASTM A 153	8		
13	3"x1 1/4" Hex Head, ASTM A 307, Gen. ASTM A 153	8		
14	3"x1 1/2" Hex Head, ASTM A 325, Gen. ASTM A 153	8		
15	Heavy Hex, ASTM A 563, Cr. Dh. Gen. ASTM A 153	8		
16	Anchor Assembly, Type B	1		SBABPK
17	1" 304 S.S. Flange, AISI 1045 Rod, AISI 1008 Cor	1		
18	Bracket Splice	4		
19	3"x2 1/2" Hex Head, 1/2" Thick, Aluminum Sheet	4		
20	3"x3 1/2" Hex Head, 1/4" Gauge, 1.025" Thick, Aluminum Sheet	2		
21	3"x2 1/2" Hex Head, 1/4" Gauge, 1.025" Thick, Aluminum Sheet	2		
22	3"x1 1/2" Hex Head, 1/4" Gauge, 1.025" Thick, Aluminum Sheet	2		
23	3"x1 1/4" Hex Head, 1/4" Gauge, 1.025" Thick, Aluminum Sheet	2		
24	3"x3 1/2" Hex Head, 1/4" Gauge, 1.025" Thick, Aluminum Sheet	2		
25	3"x2 1/2" Hex Head, 1/4" Gauge, 1.025" Thick, Aluminum Sheet	2		
26	3"x1 1/4" Hex Head, 1/4" Gauge, 1.025" Thick, Aluminum Sheet	2		
27	Cap Screw	4		

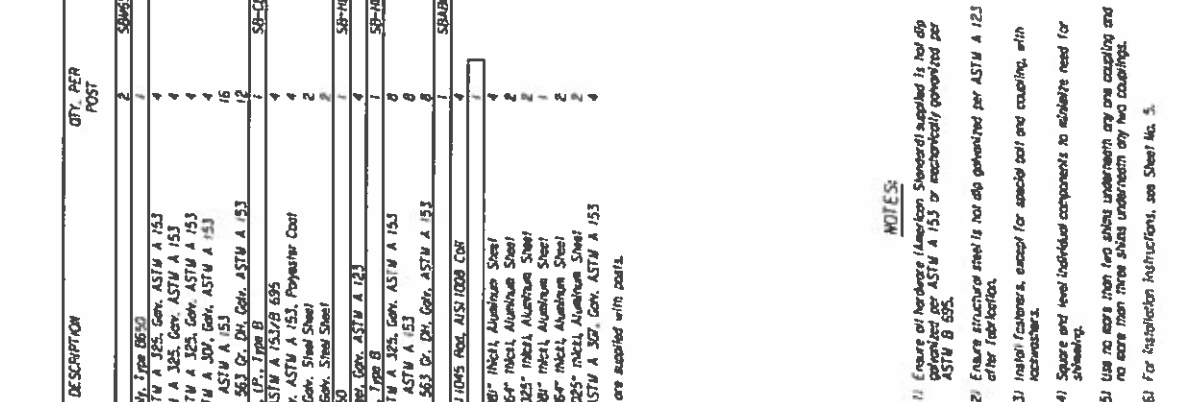

BILL OF MATERIALS

ITEM	DESCRIPTION	QTY.	PER POST	PART NO.
1	Bracket	2		SBW550
2	Bracket Hardware Assembly, Type BB50			
2a	3"x2 1/2" Hex Head, ASTM A 325, Gen. ASTM A 153	4		
2b	3"x3 1/2" Hex Head, ASTM A 325, Gen. ASTM A 153	4		
2c	3"x1 1/2" Hex Head, ASTM A 325, Gen. ASTM A 153	4		
2d	3"x1 1/4" Hex Head, ASTM A 307, Gen. ASTM A 153	4		
2e	3"x1 1/4" Hex Head, ASTM A 325, Gen. ASTM A 153	16		
2f	Heavy Hex, ASTM A 563, Cr. Dh. Gen. ASTM A 153	12		
3	Coasting E Bolt Assembly, Type B	1		SB-CBP
4	1" ASTM A 499, Gen. ASTM A 153/B 699	4		
5	1" LP, AMS 63760, Gen. ASTM A 153, Polyester Coat	4		
6	1" Hex Heads, 1/4" Gauge, Gen. Steel Sheet	2		
7	1" Hex Heads, 1/8" Gauge, Gen. Steel Sheet	2		
8	1" Hex Heads, 1/8" Gauge, Gen. Steel Sheet	2		
9	Hinge Pin	1		SB-H82
10	Hinge Hardware Assembly, Type B	1		SB-H82
11	3"x2 1/2" Hex Head, ASTM A 325, Gen. ASTM A 153	8		
12	3"x3 1/2" Hex Head, ASTM A 325, Gen. ASTM A 153	8		
13	3"x1 1/4" Hex Head, ASTM A 307, Gen. ASTM A 153	8		
14	3"x1 1/2" Hex Head, ASTM A 325, Gen. ASTM A 153	8		
15	Heavy Hex, ASTM A 563, Cr. Dh. Gen. ASTM A 153	8		
16	Anchor Assembly, Type B	1		SBABPK
17	1" 304 S.S. Flange, AISI 1045 Rod, AISI 1008 Cor	1		
18	Bracket Splice	4		
19	3"x2 1/2" Hex Head, 1/2" Thick, Aluminum Sheet	4		
20	3"x3 1/2" Hex Head, 1/4" Gauge, 1.025" Thick, Aluminum Sheet	2		
21	3"x2 1/2" Hex Head, 1/4" Gauge, 1.025" Thick, Aluminum Sheet	2		
22	3"x1 1/2" Hex Head, 1/4" Gauge, 1.025" Thick, Aluminum Sheet	2		
23	3"x1 1/4" Hex Head, 1/4" Gauge, 1.025" Thick, Aluminum Sheet	2		
24	3"x3 1/2" Hex Head, 1/4" Gauge, 1.025" Thick, Aluminum Sheet	2		
25	3"x2 1/2" Hex Head, 1/4" Gauge, 1.025" Thick, Aluminum Sheet	2		
26	3"x1 1/4" Hex Head, 1/4" Gauge, 1.025" Thick, Aluminum Sheet	2		
27	Cap Screw	4		

*** Ensure bracket splices and 13" long cap screws (figure supplied with parts).

- NOTES:**
- 1) Ensure all hardware (American Standards) supplied is hot dip galvanized per ASTM A 153 or electrolytically galvanized per ASTM B 695.
 - 2) Ensure structural steel is hot dip galvanized per ASTM A 123 after fabrication.
 - 3) Install fasteners, except for special bolt and coasting, with washers.
 - 4) Square and level individual components to eliminate need for shimming.
 - 5) Use no more than two shims underneath any one coasting and no more than three shims underneath any two coastings.
 - 6) For installation instructions, see Sheet No. 5.

REVISONS	
Revised for WYDOT's 2003 Standard Specifications.	24-Jun-03
Updated for new information from breakaway system manufacturer and new post sizes.	26-Oct-09
Updated based on breakaway system manufacturer for single bracket installation and also revised for WYDOT's 2010 Standard Specifications.	13-Nov-13

WYOMING DEPARTMENT OF TRANSPORTATION	
MULTI-DIRECTIONAL BREAKAWAY ROADSIDE SIGNS WITH MULTIPLE STEEL POSTS (Breakaway System Details for 10", 14", 18" and 21" WF Sign Posts)	
Sheet:	14-Sign-17
	Sheet 4 of 5

REVISED BY	DATE	DESCRIPTION
X	X	X

REVISED BY	DATE	DESCRIPTION
X	X	X

REVISED BY	DATE	DESCRIPTION
X	X	X

REVISED BY	DATE	DESCRIPTION
X	X	X

REVISED BY	DATE	DESCRIPTION
X	X	X

REVISED BY	DATE	DESCRIPTION
X	X	X

REVISED BY	DATE	DESCRIPTION
X	X	X

REVISED BY	DATE	DESCRIPTION
X	X	X

REVISED BY	DATE	DESCRIPTION
X	X	X

REVISED BY	DATE	DESCRIPTION
X	X	X

REVISED BY	DATE	DESCRIPTION
X	X	X

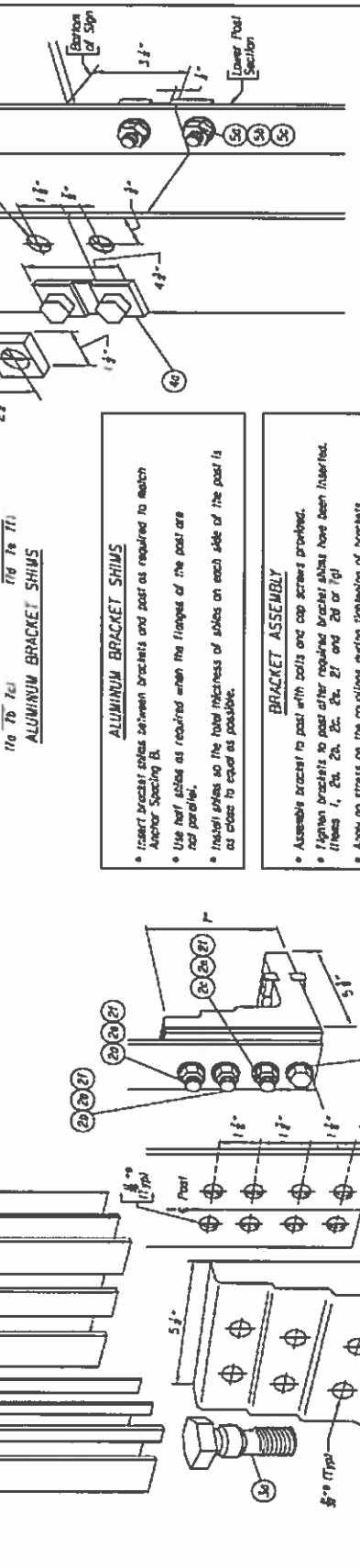
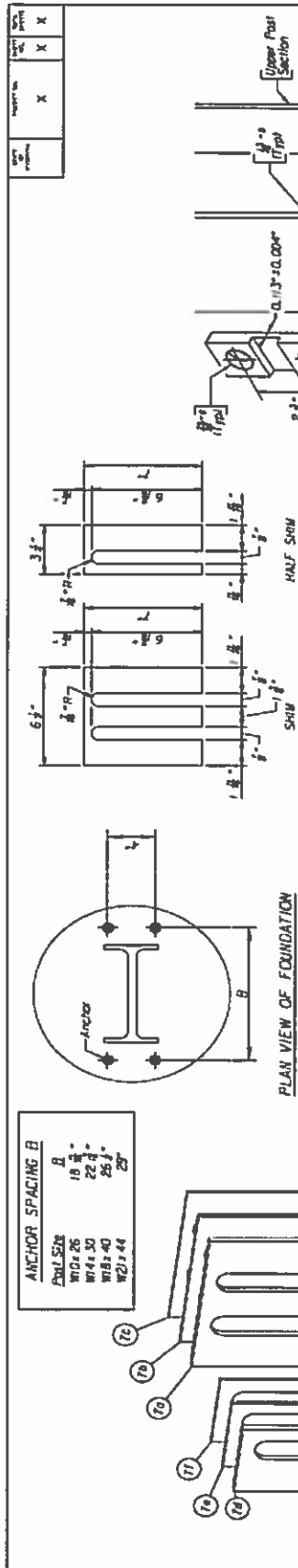

Insert bracket shims between brackets and post as required to match Anchor Spacing B.

Use half spacing as required when the flanges of the post are not parallel.

Insert shims so the total thickness of shims on each side of the post is as close to equal as possible.

Assemble bracket to post with bolts and cap screws provided.

Tighten brackets to post after required bracket shims have been inserted.

Apply no stress on the couplings during tightening of brackets to post. Tighten brackets to post with the post without threading the two anchor bolts (20) for the bracket into the couplings.

Ensure all nuts have full thread engagement on the bolts.

Use the appropriate cap screws (24 or 74) to tighten brackets to post (use longest cap screw possible that achieves required tightness). See notes below.

Use 1/2" long cap screws (20) when the combined thickness of the post flange and adjacent shims is 1/2" or less.

Use 1/2" long cap screws (74) when the combined thickness of the post flange and adjacent shims is greater than 1/2".

Tighten all nuts and cap screws 1/2 turn beyond snug. See General Notes on Sheet No. 1 for definition of snug.

Thread couplings (30) into anchors (6a). Do not tighten.

Support post assembly over foundation, insert anchor bolts (5a) through bolts in the brackets (14), and thread them snug into the couplings (30) and anchors, where needed.

Use lower wrench flits to tighten couplings into anchors as tight as possible using a conventional wrench. Do not use a pipe wrench. Couplings must be secured radially.

Tighten anchor bolts with ratcheting couplings by the upper wrench flits with an additional wrench to prevent an induced torque stress across the ratcheted portion of the coupling. Tighten anchor bolts as tight as possible using conventional wrenches.

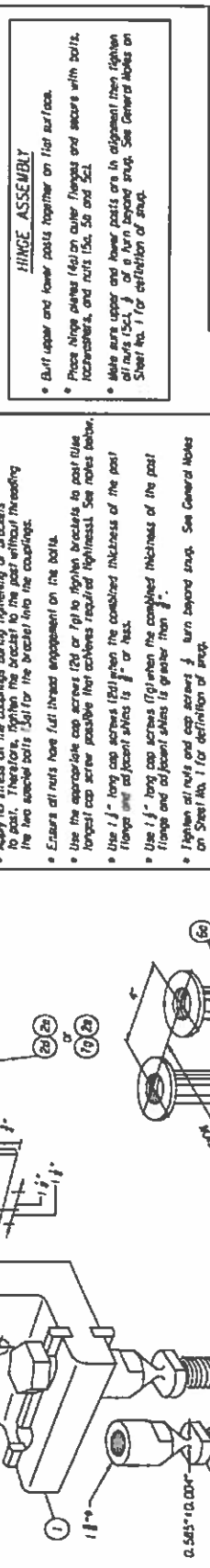

Assemble coupling anchors (6a) to foundation (use nuts and shims as shown). For spacing requirements, see General Notes on Sheet No. 1.

Lower wrench anchor assembly into fresh concrete and rotate into position so that the face of the individual anchors (6a) are level and flush with the finished top surface of the foundation.

Place hinge plates (6a) on outer flanges and secure with bolts, nuts, washers, and nuts (5c, 5b and 5d).

Make sure upper and lower posts are in alignment then tighten all nuts (5c, 5d) of a turn beyond snug. See General Notes on Sheet No. 1 for definition of snug.

Assemble bracket to post with bolts and cap screws provided.

Tighten brackets to post after required bracket shims have been inserted.

Apply no stress on the couplings during tightening of brackets to post. Tighten brackets to post with the post without threading the two anchor bolts (20) for the bracket into the couplings.

Ensure all nuts have full thread engagement on the bolts.

Use the appropriate cap screws (24 or 74) to tighten brackets to post (use longest cap screw possible that achieves required tightness). See notes below.

Use 1/2" long cap screws (20) when the combined thickness of the post flange and adjacent shims is 1/2" or less.

Use 1/2" long cap screws (74) when the combined thickness of the post flange and adjacent shims is greater than 1/2".

Tighten all nuts and cap screws 1/2 turn beyond snug. See General Notes on Sheet No. 1 for definition of snug.

REVISIONS

Revised by	DATE	DESCRIPTION
24-10-03		Updated for new information from Breakaway System Manufacturers and new post sizes.
26-02-09		Updated based on Breakaway System manufacturer for single bracket in bottom and also revised for WYDOT'S 2010 Breakaway Specifications.
13-Nov-15		

WYOMING DEPARTMENT OF TRANSPORTATION

MULTI-DIRECTIONAL BREAKAWAY ROADSIDE SIGNS WITH MULTIPLE STEEL POSTS (Breakaway System Details for 10", 14", 18" and 21" WF Sign Posts)

Date: 14-Apr-17 Sheet 5 of 5

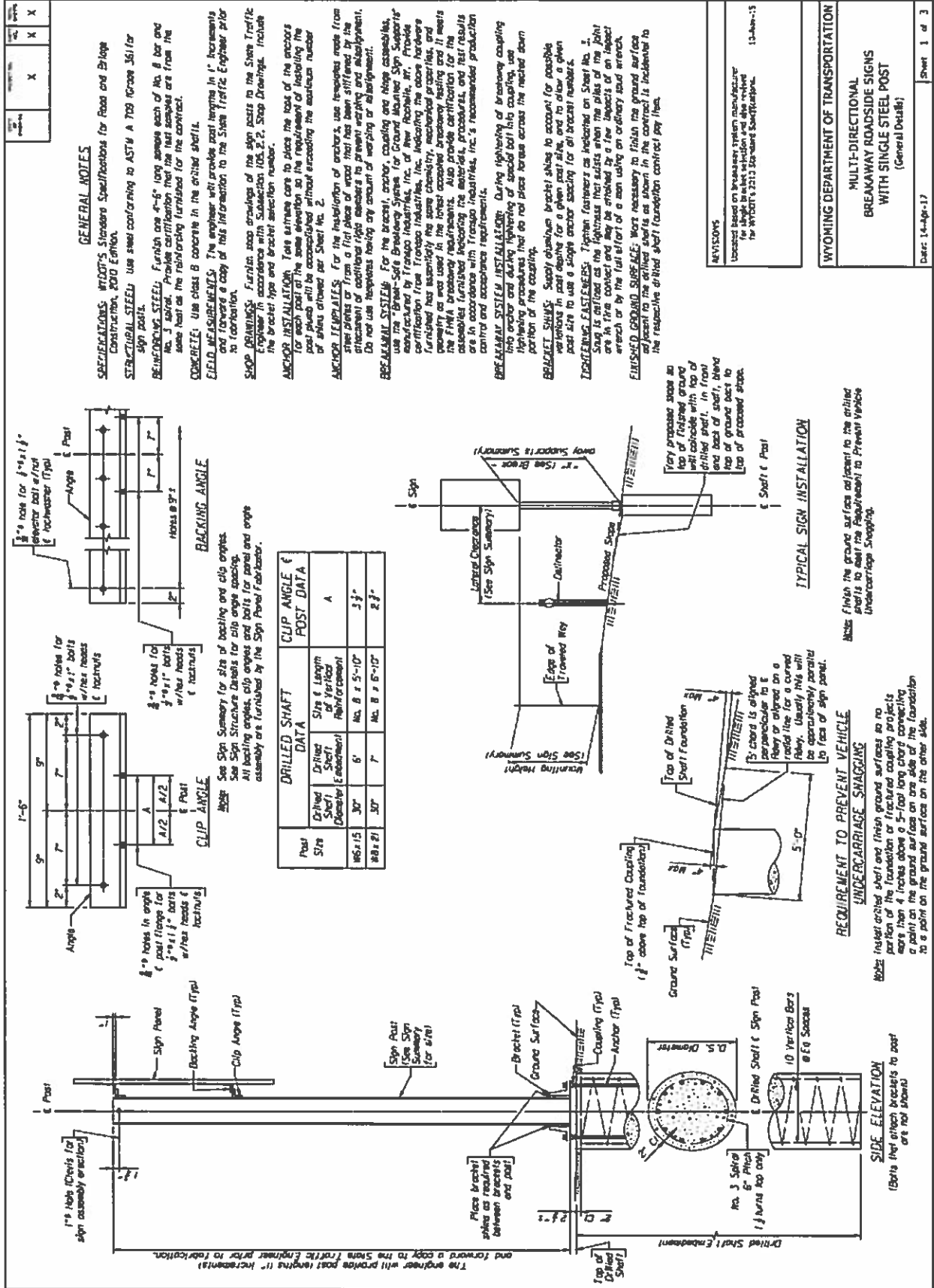

REVISED	DATE	BY
X	X	X

GENERAL NOTES

REVISIONS: WYDOT'S Standard Specifications for Road and Bridge Construction, 2010 Edition.

STRUCTURAL STEEL: Use steel conforming to ASTM A 709 Grade 50 for sign posts.

REINFORCING STEEL: Furnish one 4"-6" long rebar each of No. 8 bar and same heat as the reinforcing furnished for the contract.

CONCRETE: Use class B concrete in the drilled shaft.

FIELD MEASUREMENTS: The engineer will provide post lengths in 1' increments and forward a copy of this information to the State Traffic Engineer prior to construction.

ENGINEERING: Furnish shop drawings of the sign posts to the State Traffic Engineer in accordance with Subsection 105.2.2, Shop Drawings. Include the bracket type and bracket section number.

ANCHOR INSTALLATION: Take extreme care to place the base of the anchors for each post at the same elevation so the requirement of installing the post shall not be accomplished without exceeding the maximum number of shims allowed per Sheet No. 2.

ANCHOR TEMPLATES: For the installation of anchors, use templates made from steel plates or from a flat piece of wood that has been stiffened by the attachment of additional right members to prevent warping and misalignment. Do not use templates having any amount of warping or misalignment.

BREASTING STEEL: For the bracket, anchor, coupling and hinge assemblies, use the "Breast-Safe Breasting System for Ground Mounted Sign Supports" manufactured by Transpo Industries, Inc. of New Rochelle, NY. Provide certification from Transpo Industries, Inc. indicating the above hardware furnished has essentially the same chemistry, mechanical properties, and tensile strength as used in the latest accepted Breasting System. It meets the requirements of the contract. The use of any other Breasting System is unacceptable unless specifically approved by the engineer. Test results are in accordance with Transpo Industries, Inc.'s recommended production control and acceptance requirements.

BREASTING STEEL INSTALLATION: During tightening of breasting coupling hardware in post cap for a given post size, and to allow a given post size to use a single anchor socket for all bracket numbers.

BRACKET SHIMS: Supply aluminum bracket shims to account for possible variations in post cap for a given post size, and to allow a given post size to use a single anchor socket for all bracket numbers.

TIGHTENING FASTENERS: Tighten fasteners as indicated on Sheet No. 1. Shims are installed as the fasteners that adjust when the shims of the joint are in the correct and may be removed by a few impacts of an impact wrench or by the turn of a bar using an ordinary bar wrench.

FINISHED GROUND SURFACE: Work necessary to finish the ground surface adjacent to the drilled shafts as shown in the contract is incidental to the respective drilled shaft foundation contract pay item.

REVISIONS

Updated based on breasting system manufacturer for single bracket section and also revised for WYDOT'S 2010 Standard Specifications.

13-Jan-13

WYOMING DEPARTMENT OF TRANSPORTATION

**MULTI-DIRECTIONAL
BREAKAWAY ROADSIDE SIGNS
WITH SINGLE STEEL POST
(General Details)**

Date: 13-Apr-17 Sheet 1 of 3

CLIP ANGLE



BACKING ANGLE



DRILLED SHAFT POST DATA

Post Size	Drilled Shaft Diameter	Site Elevation	Sign Height	Post Data
16x15	30"	6'	No. B ± 5'-10"	A
18x21	50"	7'	No. B ± 6'-10"	2 3/4"

TYPICAL SIGN INSTALLATION

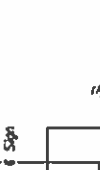

REQUIREMENT TO PREVENT VEHICLE UNDERCARRIAGE SHAGGING



SIDE ELEVATION



Notes

Notes finish the ground surface adjacent to the drilled shafts as shown in the contract to prevent vehicle undercarriage shagging.

Notes finish the ground surface adjacent to the drilled shafts as shown in the contract to prevent vehicle undercarriage shagging.

Notes finish the ground surface adjacent to the drilled shafts as shown in the contract to prevent vehicle undercarriage shagging.

Notes

Notes finish the ground surface adjacent to the drilled shafts as shown in the contract to prevent vehicle undercarriage shagging.

Notes finish the ground surface adjacent to the drilled shafts as shown in the contract to prevent vehicle undercarriage shagging.

Notes finish the ground surface adjacent to the drilled shafts as shown in the contract to prevent vehicle undercarriage shagging.

Notes

Notes finish the ground surface adjacent to the drilled shafts as shown in the contract to prevent vehicle undercarriage shagging.

Notes finish the ground surface adjacent to the drilled shafts as shown in the contract to prevent vehicle undercarriage shagging.

Notes finish the ground surface adjacent to the drilled shafts as shown in the contract to prevent vehicle undercarriage shagging.

REV. NO.	DATE	BY
X		
X		
X		

ITEM	DESCRIPTION	QTY. PER POST	PART NO.
1	Bracket	2	SB0425
2a	Bolt 3"x2 1/2" Hex Head, ASTM A 325, Gen. ASTM A 153	4	
2b	Bolt 3"x2 1/2" Hex Head, ASTM A 325, Gen. ASTM A 153	4	
2c	Bolt 3"x2 1/2" Hex Head, ASTM A 325, Gen. ASTM A 153	4	
2d	Cap Screw 3"x1 1/2" Hex Head, ASTM A 307, Gen. ASTM A 153	4	
2e	Lock Washer 3" ANSI B18-21-1, Gen. ASTM A 153	16	
2f	Nut 3" Heavy Hex, ASTM A 363 (2), Gen. ASTM A 153	12	
3	Coupling & Bolt Assembly, LP, Item B	1	SB-DBLP
3a	Special Bolt 1", ASTM A 449, Gen. ASTM A 153/B 695	4	
3b	Coupling 1", AUS 63760, Gen. ASTM A 153, Polyester Coat	4	
3c	Shim 1" Horizontal, 1/8 Gauge, Gen. Steel Sheet	2	
3d	Shim 1" Horizontal, 1/8 Gauge, Gen. Steel Sheet	2	
4	Anchor 1", 3/4 S.S. 1/2" DIA., 1/2" DIA. RIG., AISI 1008, CPH	4	SB04PK
5	Bracket Shim 3 1/2"x7", 12 Gauge 1.064" Thick, Aluminum Sheet	4	
5a	Bracket Shim 5 1/2"x7", 14 Gauge 1.064" Thick, Aluminum Sheet	4	
5b	Bracket Shim 5 1/2"x7", 22 Gauge 1.025" Thick, Aluminum Sheet	2	
5c	Half Bracket Shim 2 1/2"x7", 12 Gauge 1.064" Thick, Aluminum Sheet	1	
5d	Half Bracket Shim 2 1/2"x7", 14 Gauge 1.064" Thick, Aluminum Sheet	2	
5e	Half Bracket Shim 2 1/2"x7", 22 Gauge 1.025" Thick, Aluminum Sheet	2	
5f	Cap Screw 3"x1 1/2" Hex Head, ASTM A 307, Gen. ASTM A 153	4	

*** Ensure bracket shims and 1/2" and cap screws (5f) are supplied with paste.

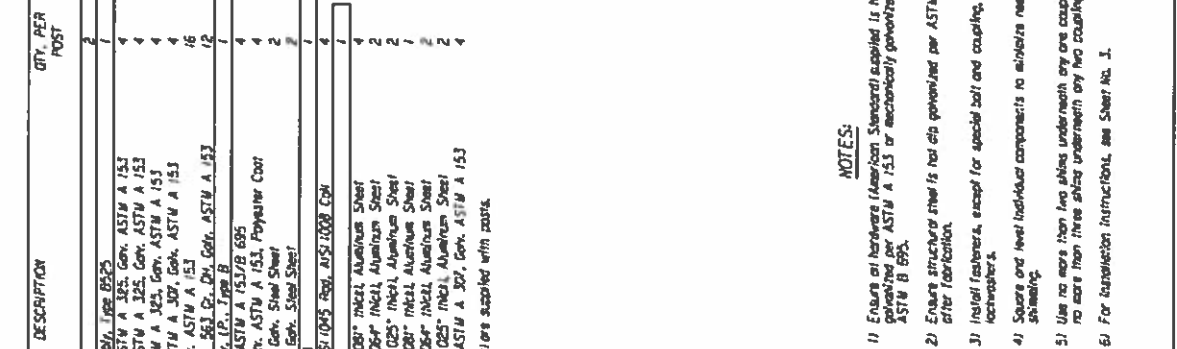

NOTES:

- 1) Ensure all hardware (American Standard) supplied is hot dip galvanized per ASTM A 153 or mechanically galvanized per ASTM B 995.
- 2) Ensure attaching steel is hot dip galvanized per ASTM A 153 after fabrication.
- 3) Install fasteners, except for special bolt and coupling, with nockwashers.
- 4) Square and level individual components to minimize need for shimming.
- 5) Use no more than two shims underneath any one coupling and no more than three shims underneath any two couplings.
- 6) For installation instructions, see Sheet No. 1.

REVIEWS

Uploaded based on breakaway system manufacturer for single bracket selection and also review for WYDOT's 2010 Standard Specifications.

13-Nov-13

WYOMING DEPARTMENT OF TRANSPORTATION

MULTI-DIRECTIONAL BREAKAWAY ROADSIDE SIGNS WITH SINGLE STEEL POST (Breakaway System Details for 6" and 8" HT Sign Posts)

Date: 14-Apr-17 Sheet 2 of 3

REVISIONS	DATE	BY	CHK
		X	X

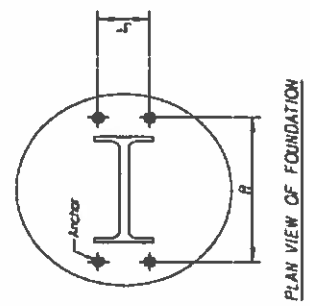
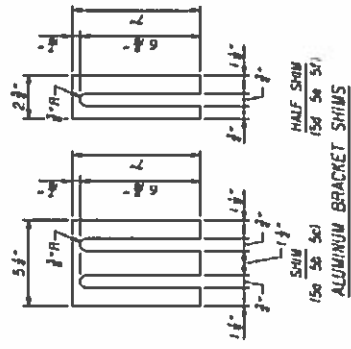

ANCHOR SPACING B	
CHAL SIZE	B
WB 4 x 13	14 3/8"
WB 4 x 21	16 1/2"

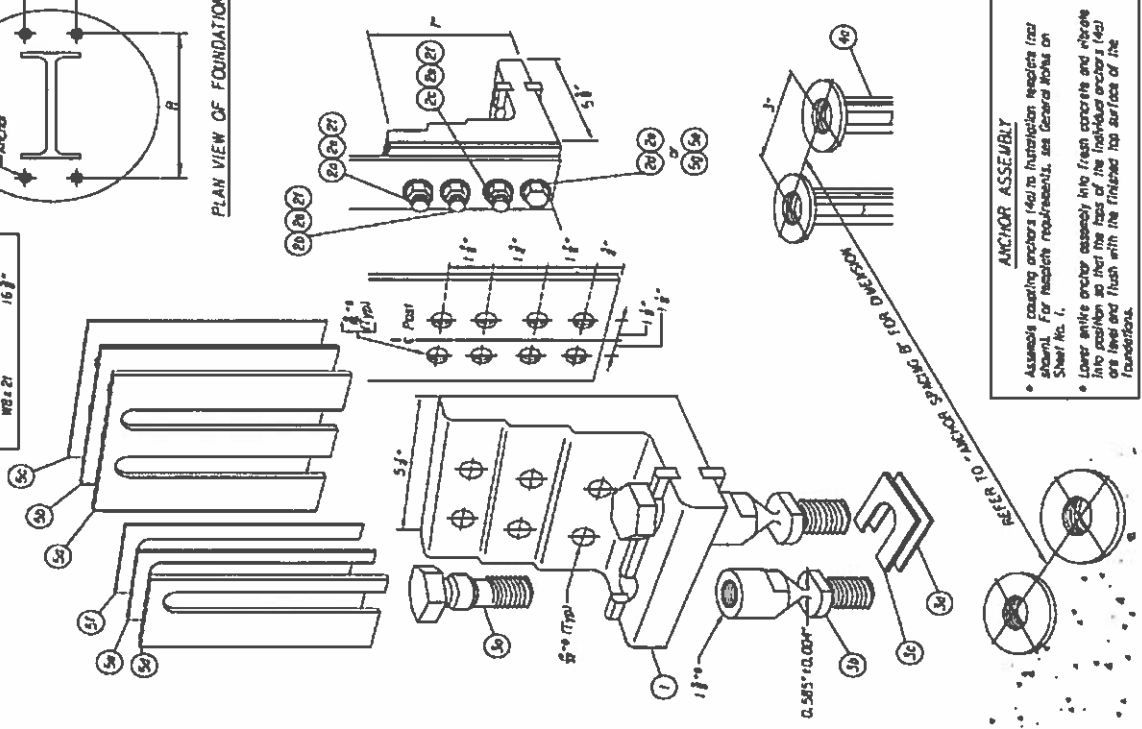

ALUMINUM BRACKET SHIMS

- Insert bracket shims between brackets and post as required to match Anchor Spacing B.
- Use half shims as required when the flange of the post are not parallel.
- Install shims so the total thickness of shims on each side of the post is as close to equal as possible.

BRACKET ASSEMBLY

- Assemble bracket to post with bolts and cap screws provided.
- Tighten brackets to post after required bracket shims have been inserted. (Items 1, 2a, 2b, 2c, 2d, 2e, 2f and 2g or 5g)
- Apply no stress on the couplings during tightening of brackets to post. Therefore, tighten the bracket to the post without threading the two anchor bolts (3a) for the bracket into the couplings.
- Ensure all nuts have full thread engagement on the bolts.
- Use the appropriate cap screws (2b or 5g) to tighten brackets to post (Use longest cap screw possible that achieves required tightness). See notes below.
- Use 1 1/2" long cap screws (2a) when the combined thickness of the post flange and adjacent shims is 1 1/2" or less.
- Use 1 1/2" long cap screws (5g) when the combined thickness of the post flange and adjacent shims is greater than 1 1/2".
- Tighten all nuts and cap screws 1/2 turn beyond snug. See General Notes on Sheet No. 1 for definition of snug.

COUPLING ASSEMBLY

- Thread couplings (3a) into anchors (4a). Do not tighten.
- Support post assembly over foundation. Insert spacer bolts (5a) through holes in the brackets (1), and thread them snug into the couplings (3a). If post is not plumb, insert shims (5c and/or 5d) between the couplings and anchors, where needed.
- Use lower wrench flits to tighten couplings into anchors as tight as possible using a conventional wrench. Do not use a pipe wrench. Couplings must be axial square.
- Tighten spacer bolts while holding couplings by the upper wrench flits with an additional wrench to prevent an induced torque stress across the necked portion of the coupling. Tighten spacer bolts as tight as possible using conventional wrenches.

ANCHOR ASSEMBLY

- Assemble coupling anchors (4a) to foundation according to drawing shown. For nomenclature requirements, see General Notes on Sheet No. 1.
- Lower anchor assembly fits flush against and above the top surface of the foundation. The top surface of the anchor must be flush with the finished top surface of the foundation.

REVISED

Updated based on bracket system manufacturer
For shims bracket selection and other revised
for WYDOT's 2013 Standard Specifications.

12-Nov-15

WYOMING DEPARTMENT OF TRANSPORTATION
MULTI-DIRECTIONAL
BREAKAWAY ROADSIDE SIGNS
WITH SINGLE STEEL POST
(Breakaway System Details for
6" and 8" WF Sign Posts)

Date: 14-Apr-17

Sheet 3 of 3

7 - Lateral Clearance and Mounting Height

Lateral clearance for roadside signs is the distance measured from the edge of traveled way or from delineators to the near vertical edge of the sign panel. Typically, this is measured from delineators; edge of traveled way is seldom used due to variation in shoulder width. In sections with curb and gutter, lateral offset is measured from the front face of curb. In sections with attached sidewalks, lateral clearance is measured from the back of sidewalk. The frequency of collisions with sign supports diminishes as the lateral offset increases. Roadside signs are placed as far from the edge of traveled way as practical while still providing conspicuity. A uniform offset along highways is preferable.

Mounting height is the vertical distance from the edge of traveled way to the bottom of the sign. In the case of sections with curb and gutter, mounting height is measured from the top of the curb. In sections where sidewalks are present, mounting height is measured from the top of sidewalk.

7A - Interstate Highways

On interstate highways a clearzone of 50 feet is used to determine lateral clearance. Primary signs are placed inside of the clearzone at a distance of 30 feet from the edge of traveled way and breakaway supports are required. Secondary signs are placed outside of the clearzone at a distance of 50 feet from the edge of traveled way; breakaway supports are preferred but may be omitted as directed by the Engineer. When delineators are used as a reference for lateral clearance and shoulder widths are unknown, as in the case of pavement preservation, a shoulder width of 8 feet should be assumed. Secondary signs placed in the median are prohibited.

The following table outlines lateral clearance (Lc) (measured from delineators) and mounting height (Mh) requirements for interstate highways:

Table 7-1 Mainline Interstate Lateral Clearance and Mounting Height

		Mainline Interstate					
		8' Shoulder		10' Shoulder		Median	
		Lc	Mh	Lc	Mh	Lc	Mh
Primary		18	7	16	7	10	7
Secondary		38	7	36	7	-	-

7B - Ramps and Crossroads

The clearzone for ramps and crossroads (roads without curb and gutter and speeds of less than 45 mph) is 20 feet. Primary signs shall have a lateral clearance of 16 feet from the edge of traveled way and require break away supports. Secondary signs shall have a lateral clearance of 31 feet from the edge of traveled way and breakaway supports are preferred. However, breakaway supports may be omitted as directed by the Engineer.

The following table outlines lateral clearance (measure from delineators) and mounting height requirements for ramps and crossroads.

Table 7-2 Ramp and Crossroad Lateral Clearance and Mounting Height

		Ramps & Crossroads	
		Lc	Mh*
Primary		10	5
Secondary		25	5

**For hinged steel breakaway supports the length of the lower post from the hinge to the top of the drilled shaft foundation must be a minimum of 7'.*

7C - Non-Interstate Highways

The clearzone on non-interstate highways varies as a function of the posted speed limit. For purposes of signing ADT and fore slope will not be considered. Roadway sections without curb and gutter and with posted speed limits of 50 mph and greater have a clearzone of 30 feet. The clearzone for roadways without curb and gutter and a posted speed limit of less than 45 mph is 20 feet. A primary sign located on roadway sections with a posted speed limit greater than 45 mph, a lateral clearance of 21 feet measured from the edge of traveled way is preferred and breakaway supports are required. On roadway sections where the posted speed limit is 45 mph and under, a lateral clearance of 16 feet from the edge of traveled way is preferred and breakaway supports are required. Secondary sign, regardless of the posted limit should have a lateral clearance of 31 feet measured from the edge of traveled way; breakaway support are preferred but may be omitted as directed by the Engineer. In the event that the above guidelines cannot be met, a 12 foot minimum lateral clearance measured from the edge of traveled way may be used with a breakaway post.

The following tables outline lateral clearance (measured from delineators) and mounting height for non-interstate highways.

Table 7-3 Non-Interstate Lateral Clearance and Mounting Height

Non- Interstate Highways				
Posted Speed Limit > 45			Posted Speed Limit 45 and Under	
	Lc	Mh*	Lc	Mh*
Primary	15	5	10	5
Secondary	25	5	25	5

Median Divided Non- Interstate Highways				
Posted Speed Limit > 45			Posted Speed Limit 45 and Under	
	Lc	Mh	Lc	Mh
Primary	15	7	10	7
Secondary	25	7	25	7

**For hinged steel breakaway supports the length of the lower post from the hinge to the top of the drilled shaft foundation must be a minimum of 7'.*

7D - Urban and Sections with Curb and Gutter

In curbs and gutter sections with posted speed limits 45 mph and under all signs will be placed 2 feet behind the front face of curb or 2 feet behind attached sidewalk. Though these sign are outside of the clearzone break away support are preferred on all signs. On roadway sections with posted speed limits greater than 45 mph engineering judgment must be used. In all cases mounting height will be set at 7 feet, measured from top of curb or sidewalk.

7E - Barrier Protected Roadway Sections

In instances where a sign is placed behind traffic barrier, regardless of the road classification, the following lateral clearances are to be used. For mounting height, refer to previous tables. The lateral clearances apply to both primary and secondary signs and are measured to near edge of sign panel unless noted.

Table 7-4 Barrier Protect Lateral Clearance

Barrier Protected Roadway Sections	
Barrier Type	Lc*
Box Beam Guardrail	5'
W - Beam Guardrail	2'
Cable Barrier*	10'

**Lateral Clearance is measured to rear face rail post (See Figure 7-1)*

7F - Chevron Signing for Curves

When chevrons are used to sign a curve, regardless of road classification, a 4 foot mounting height is used with a lateral clearance of 10 feet behind the delineators. This variation is used to increase conspicuity of this type of sign.

Figure 7-1 Lateral Clearance and Mounting Height

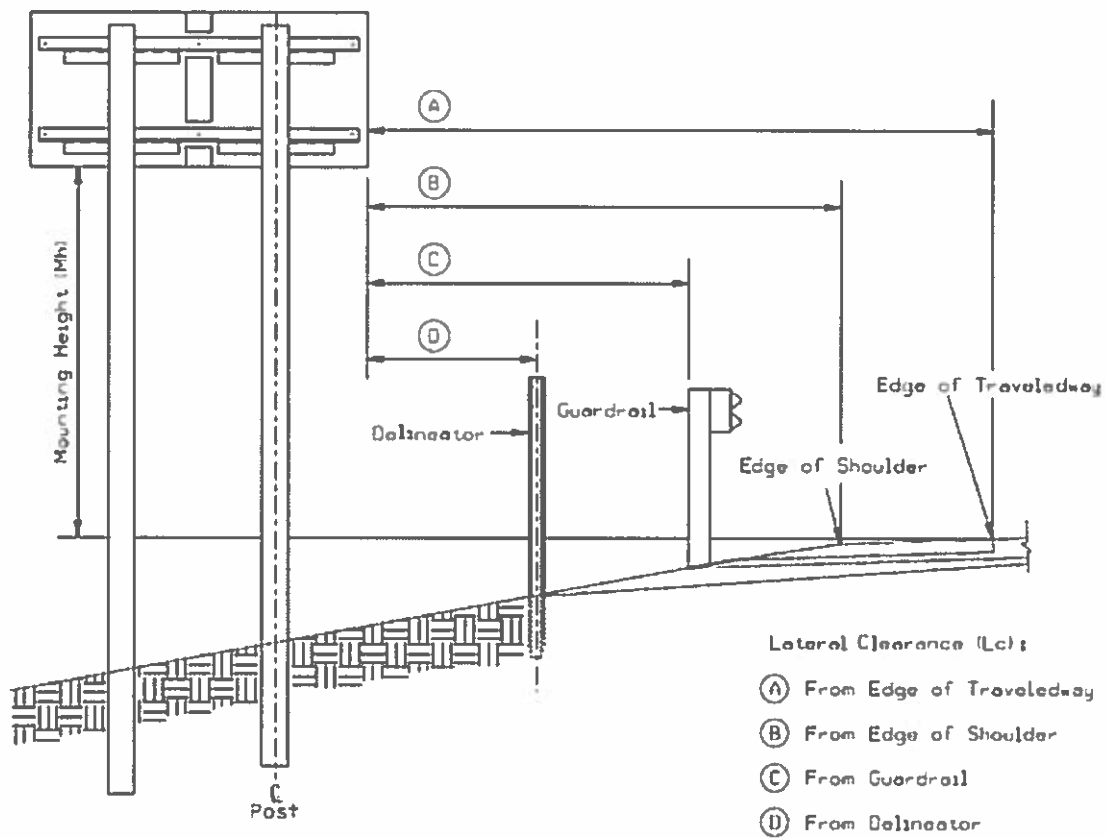
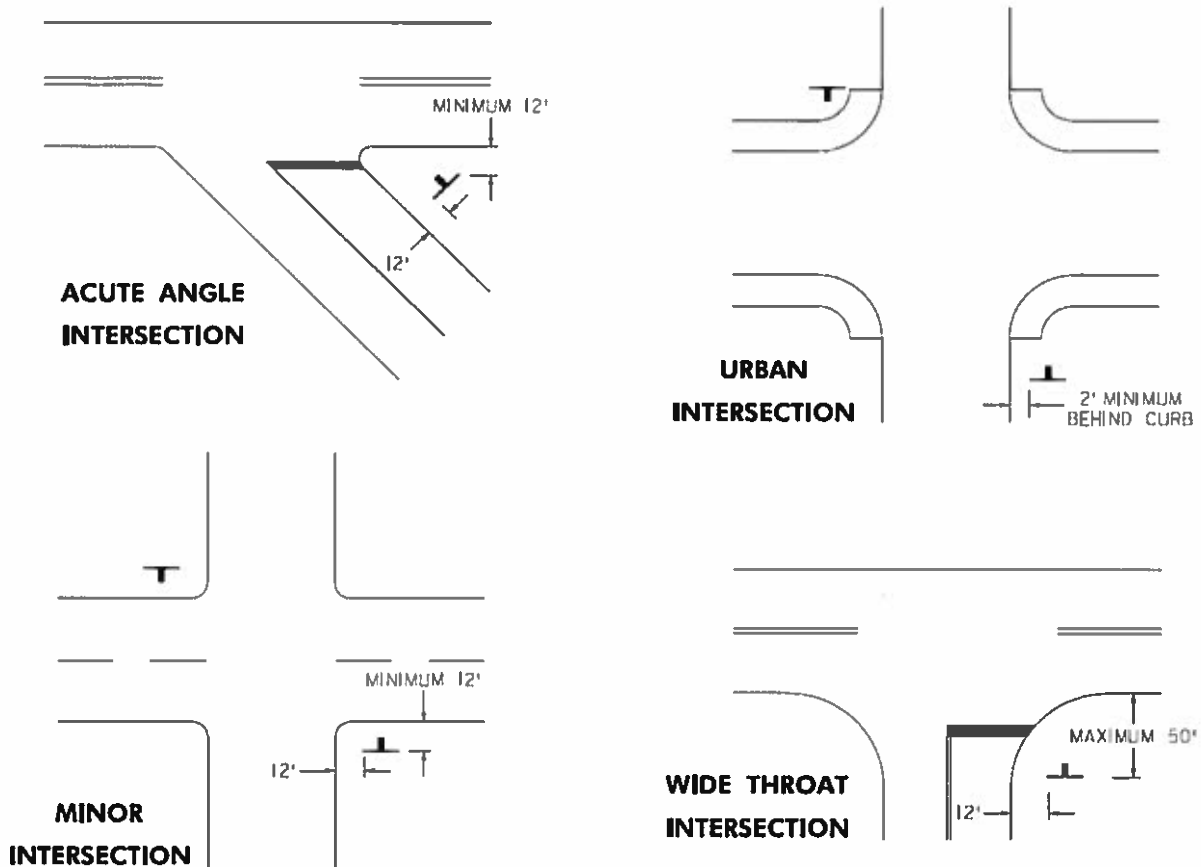

Figure 7-2 Typical Locations for Stop Sign Placement



8 - Post Length Determination

Post lengths given on contract drawings are for estimation purposes only and should not be used for final lengths. Post length must be refined before posts are ordered. Post length is a function of embedment depth, mounting height, offset height, sign width, and sign height. Generally post length is as follows:

$$L = Emb + Mh + \Delta + 1/12(W) + H$$

De = Embedment Depth (where applicable)

Mh = Mounting Height

Δ = Offset Height

W = Sign Width

H = Post Length Behind Sign

The length calculated is rounded up as follows:

Timbers Posts 2' increments

All Others: 1' increments

8A - Embedment Depth

Timber Posts

For embedment depth of timber post, see Sign Support and Foundations Section.

Round Tubular Post

For round tubular posts subtract 3" due to the distance below the slip base casing.

Perforated Square Tubular Post

For perforated square tubular posts add 12" for the length of post in anchor

8B - Mounting Height

For mounting heights, see Lateral Clearance and Mounting Height section.

8C - Offset Height (Δ)

The lateral distance that a sign is placed affects post length due to the slope of the roadway and the slope to the ditch. For estimating purposes assume a 1V:6H slope from edge of shoulder to edge of sign. Tables 8-1 through 8-5 were developed using a 1V:6H slope from edge of shoulder to edge of sign. On non-interstate highways assume a 4 foot shoulder and on interstate highways assume an 8 foot shoulder. Delineators are typically placed 4 feet from the edge of shoulder. The following equation is used to determine Δ :

$$\Delta = (w) \cdot .02 + (Lc+4)/6$$

w = Shoulder Width

Lc = Lateral Clearance

For example, a primary sign on an interstate highway with 8' shoulders:

$$w = 8'$$

$$Lc = 18'$$

$$\Delta = (8) \cdot .02 + (18+4)/6 = 3.83'$$

The following table summarizes the effect of lateral clearance on post length. Unless noted, all lateral clearances are measured from delineator.

Table 8-1 Mainline Interstate Offset Height (Δ)

<i>Mainline Interstate Highways</i>	
Lateral Clearance	Δ
Gore Sign	1.0'
10'	2.41'
18'	3.83'
38'	7.16'

Table 8-2 Ramp and Crossroad Offset Height (Δ)

<i>Ramps and Crossroads</i>	
Lateral Clearance	Δ
10'	2.41'
12**	1.41'
25'	4.91'

**Measured from edge of traveled way*

Table 8-3 Non-Interstate Offset Height (Δ)

<i>Non- Interstate Highways</i>	
Lateral Clearance	Δ
10'	2.41'
12**	1.41'
15'	3.25'
25'	4.91'

**Measured from edge of traveled way*

Table 8-4 Barrier Protected Section Offset Height (Δ)

<i>Barrier Protected Roadway Sections</i>	
Barrier Type	Δ
Box Beam	.5'
W - Beam	.5'
Cable	1.83'

Table 8-5 Urban and Sections with Sidewalk/Gutter Offset Height (Δ)

<i>Urban and Sections with Sidewalk/Curb</i>	
Lateral Clearance	Δ
2**	0

***Measured from front face of curb or back of sidewalk*

For steel beam post selection: $X = \Delta + Mh$

8D - Post Length Behind Signs

The following table is to be used when determining the length of post behind signs

Table 8-5 Post Length Behind Sign

POST LENGTH BEHIND SIGNS			
Sign Height	Post Length	Sign Height	Post Length
1' - 0"	1'	24" Shield	2'
1' - 6"	1'	36" Shield	3'
2' - 0"	2'	30" Dia	3'
2' - 6"	2'	36" Dia	4'
3' - 0"	3'	48" Dia	5'
3' - 6"	3'	30" Oct	2'
4' - 0"	3'	48" Oct	3'
4' - 6"	4'	36" Yield	2'
5' - 0"	4'	48" Yield	3'
5' - 6"	5'	30" School	2'
6' - 0"	5'	36" School	3'
6' - 6"	6'	48" School	3'
7' - 0"	6'	36" Circle	2'
7' - 6"	7'	48" X 36"	3'
8' - 0"	7'	No Passing	
8' - 6"	7'	Zone	
9' - 0"	7'		
9' - 6"	8'		
10' - 0"	9'		
10' - 6"	9'		
11' - 0"	9'		
11' - 6"	10'		
12' - 0"	10'		

Figure 8-1 Post Length Determination

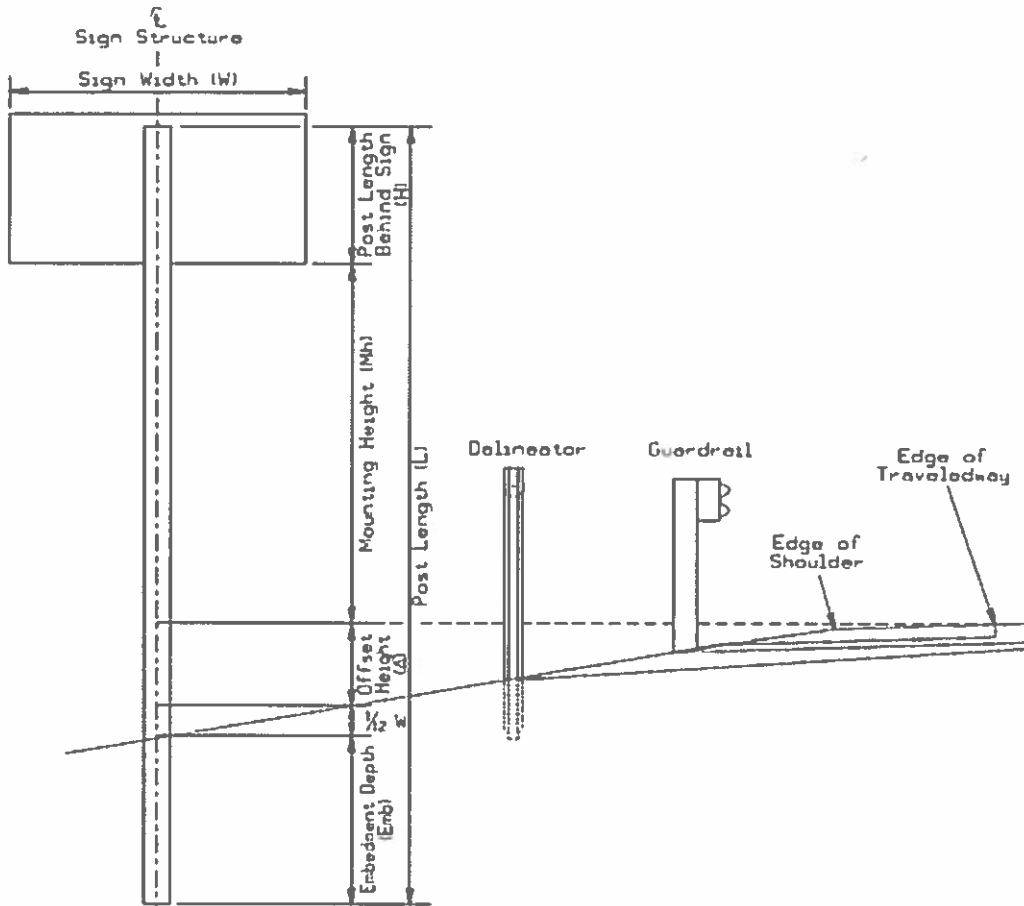

Example

A 9' X 5' primary sign located on an interstate section. Sign support is 2 – 6 X 8 timber posts

$$L = Emb + Mh + \Delta + 1/12(W) + H$$

- Embedment Depth = 7'
- Mounting Height = 7'
- Offset Height (Δ) = 3.83'
- $1/12(W) = .75'$
- Post Length Behind Sign (H) = 4'

$$L = 7 + 7 + 3.83 + .75 + 4 = 22.58', \text{ use } 24'$$

9 - Hardware and Backing Angles

9A - Backing and Clip Angles

Backing angles attach to the sign to provide rigidity and a point of attachment to clip angles which attach to posts. Backing angles run the width of the sign less 4 inches on either side. Typically multiple backing angles are used, in the event that only one is used strips must be provided to prevent sign rotation. Clip angles attach to the posts and are available in 2 lengths, 9" and 18". The following tables and charts give the number, size, and placement of backing angles. Sign overhangs cannot be less than 13", measured from centerline support.

Table 9-1 Backing Angle Selection

One Post				
Width "W" (Feet)	Sign Height "H" (Feet)			
	5.0 & Below	5.01 - 7.0	7.01 - 11.0	11.01 - 15.0
4 & Below	2 - L 2 x 2 x 3/8	2 - L 2 x 2 x 3/8	3 - L 2 x 2 x 3/8	4 - L 2 x 2 x 3/8
4.01-5.0	2 - L 2 x 2 x 3/8	2 - L 2 1/2 x 2 1/2 x 1/4	X	X

Multiple Posts			
Width "W" (Feet)	Sign Height "H" (Feet)		
	7.0 & Below	7.01 - 11.0	11.01 - 15.0
7 & Below	2 - L 2 x 2 x 3/8	3 - L 2 x 2 x 3/8	4 - L 2 x 2 x 3/8
7.01-11.0	2 - L 2 1/2 x 2 1/2 x 1/4	3 - L 2 1/2 x 2 1/2 x 1/4	4 - L 2 1/2 x 2 1/2 x 1/4
11.01-14.0	3 - L 2 1/2 x 2 1/2 x 1/4	4 - L 2 1/2 x 2 1/2 x 1/4	5 - L 2 1/2 x 2 1/2 x 1/4
14.01-19.0	3 - L 2 1/2 x 2 1/2 x 1/4	4 - L 2 1/2 x 2 1/2 x 1/4	5 - L 2 1/2 x 2 1/2 x 1/4
19.01-24.0	3 - L 2 1/2 x 2 1/2 x 1/4	4 - L 2 1/2 x 2 1/2 x 1/4	5 - L 2 1/2 x 2 1/2 x 1/4

Overhead sign structures use 2 1/2" x 2 1/2" x 1/4" backing angles on big signs.

Note:

1. All angles shall be ASTM A36 steel.
2. A 1/8" thick aluminum sign panel 4' wide or less on a single post does not require backing angles to resist a 90 M.P.H. wind velocity.

Weights:

L 2 x 2 x 3/8 = 2.44 lbs / ft
 L 2 1/2 x 2 1/2 x 1/4 = 4.10 lbs / ft

9B - Hardware

Overlay of Existing Signs

3/16" inch rivets with aluminum mandrels are used to attach aluminum overlay panels to existing signs. Rivets are spaced at 6 inch centers around the edge of each overlay panel and 12 inches throughout the remaining portion.

Attachment of Signs to Backing Angles

New Aluminum Signs: ¼ inch rivets with steel mandrels are used to attach new aluminum sign panels to backing angles.

New Plywood Signs: ¼ inch x 1 ½ inch elevator bolts are used to attach new plywood signs to backing angles.

Attachment of Backing Angles to Clip Angles

Use a 3/8 inch diameter by 1" hex bolt with a single lock nut to attach backing angles to clip angles.

Attachment of Clip angles to Post

Use either ½ inch diameter carriage bolts or ½" diameter hex bolts with a flat washer and a single lock washer and hex nut to attach clip angles to posts. Locking nuts may also be used with OGEE washers, this is the preferred connection.

All hardware must be galvanized steel or Type II/III zinc cadmium plated.

Figure 9-1 Post Spacing and Backing Angle Placement

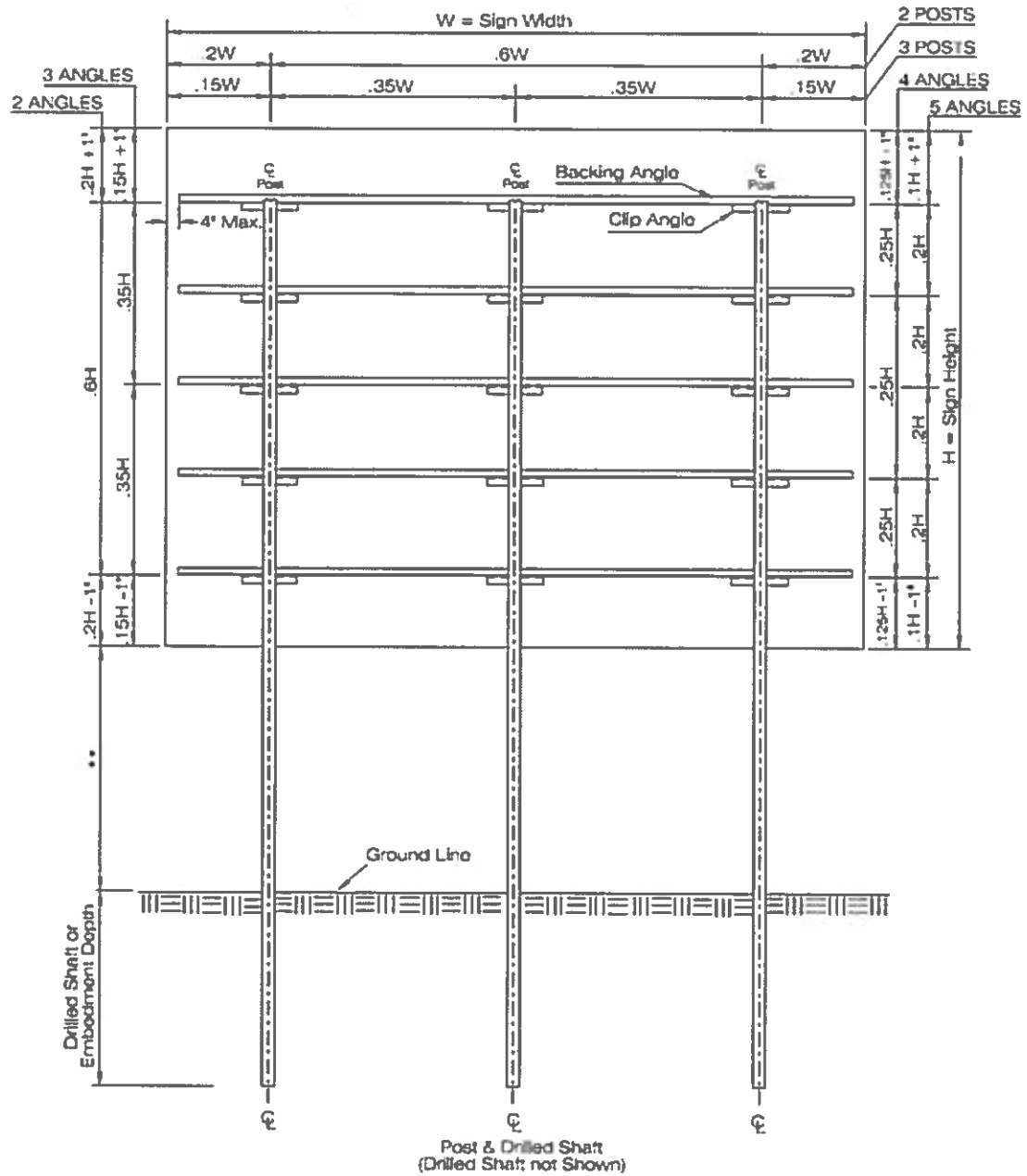

** This shall be sufficient height to allow for safe passage of vehicle.
(7'-0" minimum, WF Steel Posts Only).

10 - Reference Markers

Reference markers are a type of guide sign that provide location information to drivers and other programs with the Department of Transportation.

Using the reference marker system allows Highway Safety to locate traffic accidents. It is then possible to identify highway deficiencies associated with these traffic accidents. In addition, using reference markers allows the Wyoming Department of Transportation to report dangerous highway conditions to the traveling public. Reference markers allow maintenance forces to identify and plan operations.

10A - Location and Spacing of Reference Markers

On all highways and freeways within the State of Wyoming, reference markers are placed at either 4 feet from the edge of shoulder or 2 feet behind guardrail. Spacing is generally in 1 mile increments with the following exceptions:

At bridge ends the reference markers reference the center of the structure in 1/100th of a mile increments and are placed at rear face of abutment. At points of equation change reference markers measure to the point of change in 1/100th of a mile increments.

10B - Interstate Highways

On all interstate highways single panel reference markers will be used. A single panel will have a width of 1 foot and heights of 2, 3, or 4 feet. 10 inch letters are required on all panels with the following exceptions:

- 1) Triple digit non-integer locations (i.e. 543.21) use 8 inch letters.
- 2) Triple digit non-integer location at equation locations (i.e. 543.21 AH) use 6" letters.

Reference markers will be mounted on a 2" X 2" square tubular post.

10C - Non-Interstate Highways

On all non-interstate highways individual 4" X 7" panels will be used. Use 4 inch letters for integer number and 3 inch letter in all other cases. Panels will be mounted to a standard delineator post.

10D - Materials

Use .125" aluminum for the substrate. Use ASTM Type IV green material for the background sheeting and ASTM Type IV white sheeting for the legend.

11 -Overhead Sign Structures

Before recommending any overhead signs, careful consideration should be given to ground mounted signs. Requirements regarding clearzone, sight distance, insufficient space for ground mounted signs, and lane assignments should all be carefully considered.

Signs are to be placed directly over the lanes to which they apply. Overhead signs should be used on roadways where lane use control is required and at locations where space is not available along the roadside. In addition, consideration should also be given in areas where sight distance is limited by vertical or horizontal curvature.

The minimum vertical clearance to the bottom of all new overhead sign panels is 19'-0".

Overhead signing is required per the MUTCD in the following circumstances:

- 1) Overhead arrow per lane
- 2) Pull through signs
- 3) Interchange lane drops
- 4) Interchange sequence signs
- 5) Interstate to interstate
- 6) Cloverleaf interchanges

12 - District Sign Upgrades

Each District is required to inspect one third of its signing inventory for the purpose of upgrading. Inspections are to be performed by representatives from District Traffic and Headquarters Traffic. Personnel from the Department's sign shop will represent Headquarters for all Interstate sign inspections. Personnel from Signing and Work Zones will represent headquarters for all non-Interstate sign inspections. Upgrading signs will follow a set schedule each year agreed upon by the Districts and Headquarters. Additionally, night time inspections are to be performed by the District prior to the general inspection.

After the general inspection is completed, signs that require an overlay or need replaced will have layouts completed by headquarters. Fabrication will be completed by the Sign Shop and installed either by the District or contract.

13 - Shop Drawing Review

The Headquarters Traffic Program is responsible for the review and final approval of all steel wide flange breakaway sign supports and solar service supports. Shop drawings are submitted to the State Traffic Engineer in accordance with the Standard Specifications for Road and Bridge Construction. Upon receipt of the shop drawings, the review will take no longer than 14 calendar days.

During the review process the Resident Engineer provides the final post lengths in 1 inch increments to be verified with the shop drawings. In addition to the post lengths, all aspects of the plans are verified, including but not limited to: member size, bolt hole location, bolt hole size, steel grade, and bill of materials.

Any errors or omissions are taken as exception and the shop drawing will be stamped as advanced and returned to the fabricator for correction. A set of shop drawings with no errors or omissions will be considered as no exceptions taken and stamped as final. Final copies of shop drawings are distributed as follows:

Resident Engineer:	2 copies
District Traffic Engineer:	1 copy
Contractor:	1 copy
Fabricator:	1 copy

The fabricator is responsible for providing any other party with copies of the final shop drawings.

This review does not relieve the Contractor or Fabricator from responsibility for error or omissions and any necessary corrections.

14 - Sign Inspection

Personnel from the Headquarters Traffic Program will inspect all permanent signs at the project site prior to installation. This inspection ensures that signs meet layout, material, and fabrication requirements. The contractor is required to contact the Signing Engineer of the Headquarters Traffic Program a minimum of 14 calendar days in advance to schedule the inspection. All signs must be unpacked and ready for inspection at the scheduled time. Inspections will not be scheduled on Friday.

If permanent signs have not been inspected prior to installation, the Engineer will reject the installed signs and the Contractor will schedule an inspection.

Once the inspection is complete, the Headquarters Traffic Program will notify the Engineer that the inspection has been completed and present any exceptions. This inspection does not constitute final acceptance of the completed sign installations.

APPENDIX A – INTERSECTION AND JUNCTION SIGNING

Figure A-1 Interstate Diamond Interchange with Two Lane Crossroad



Figure A-2 Interstate Diamond with Multilane Crossroad

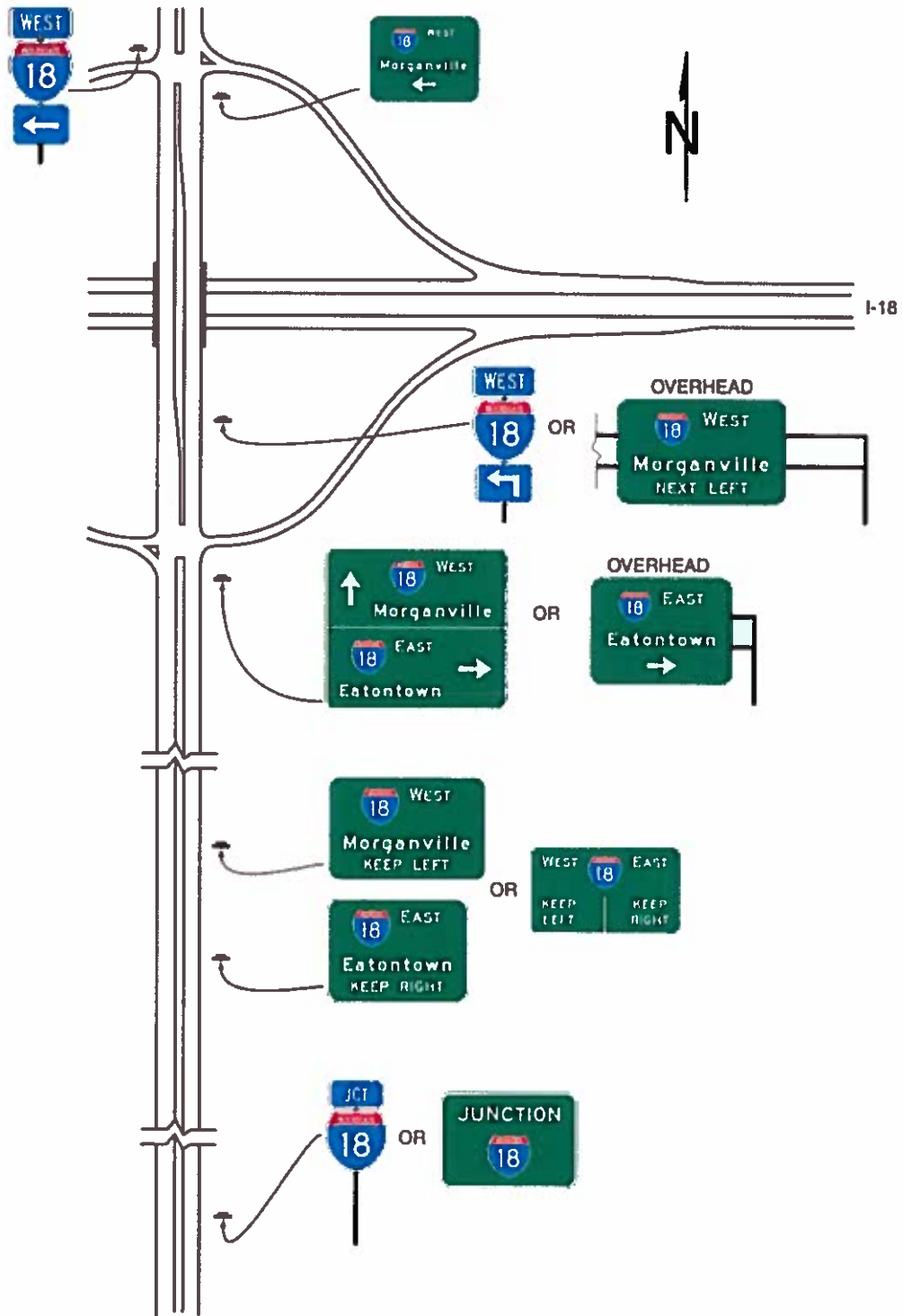

Figure A-3 Minor Interchange Crossroad

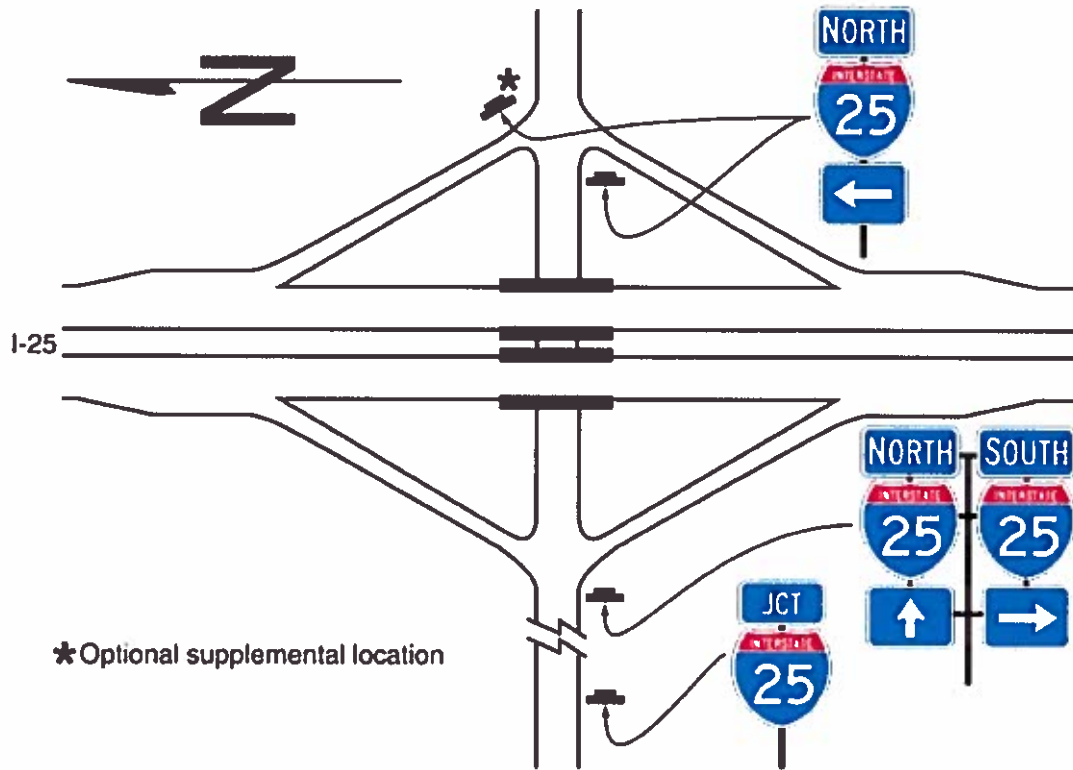

Figure A-4 Highway Junction

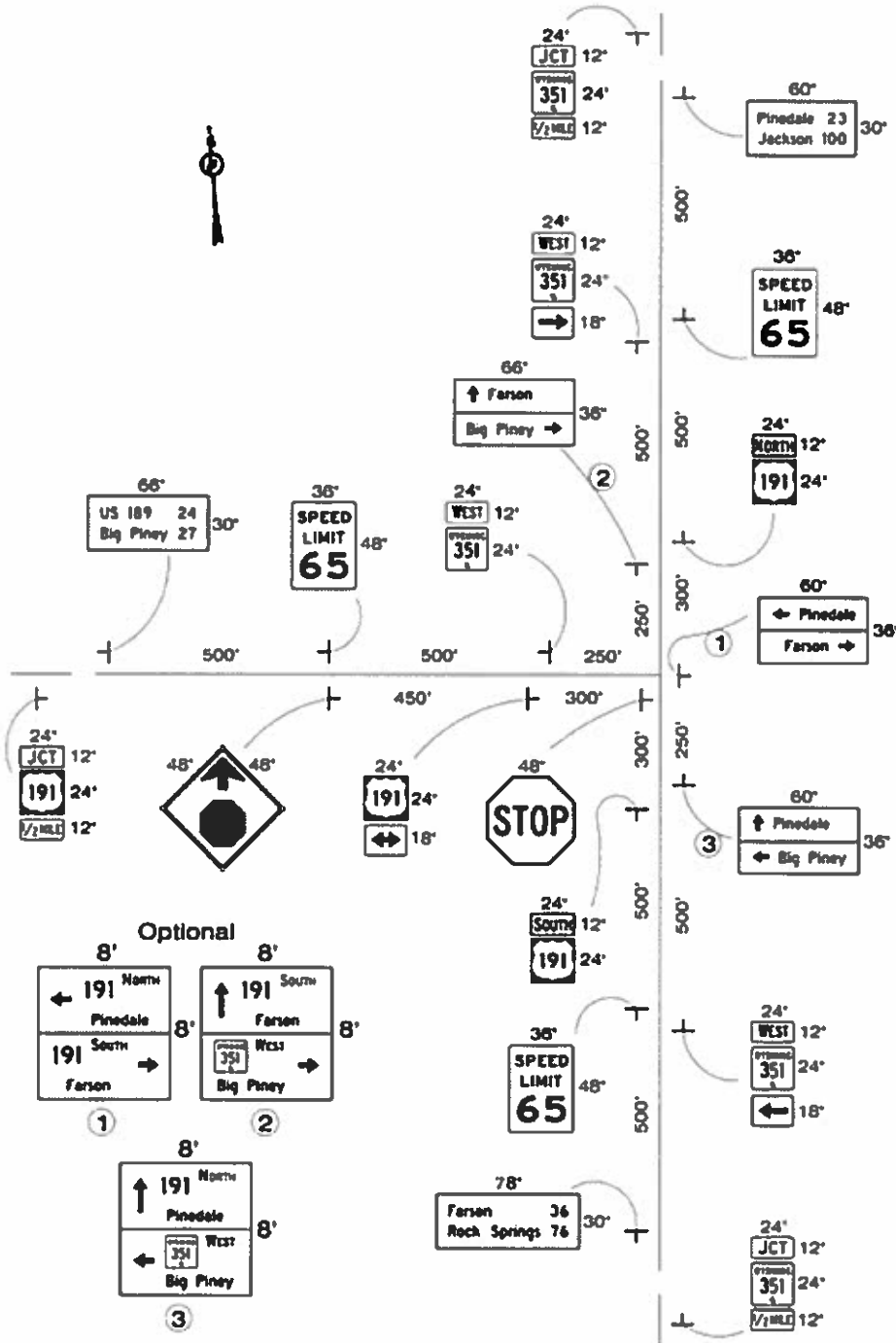

Figure A-5 Interchange Off Ramp County/Local Road

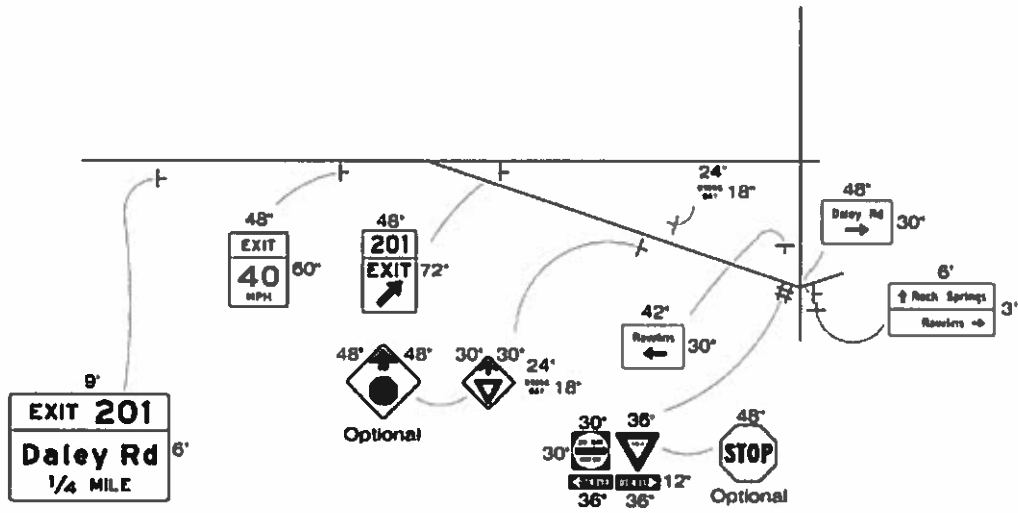

Figure A-6 Interchange Off Ramp Non-NHS Cross Road

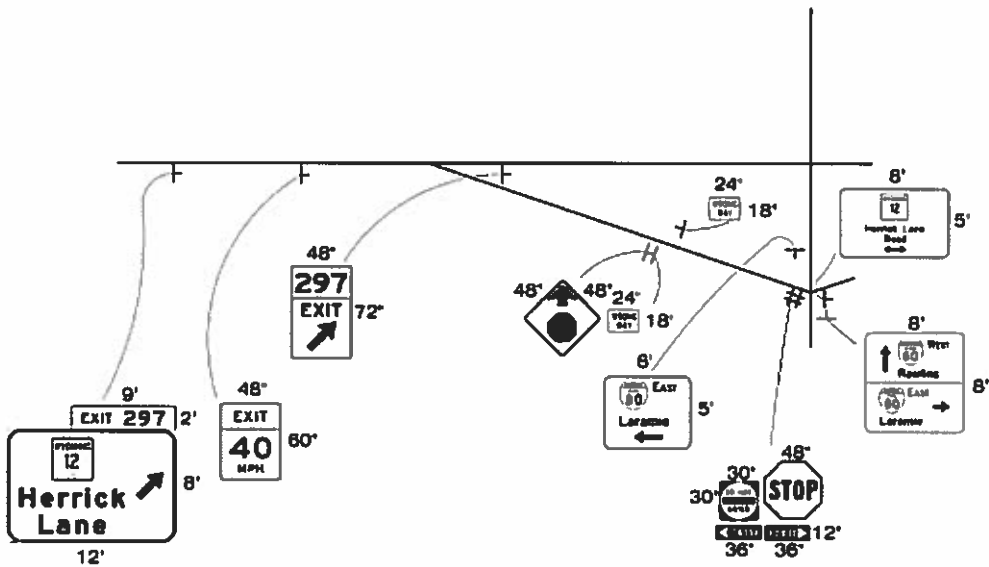
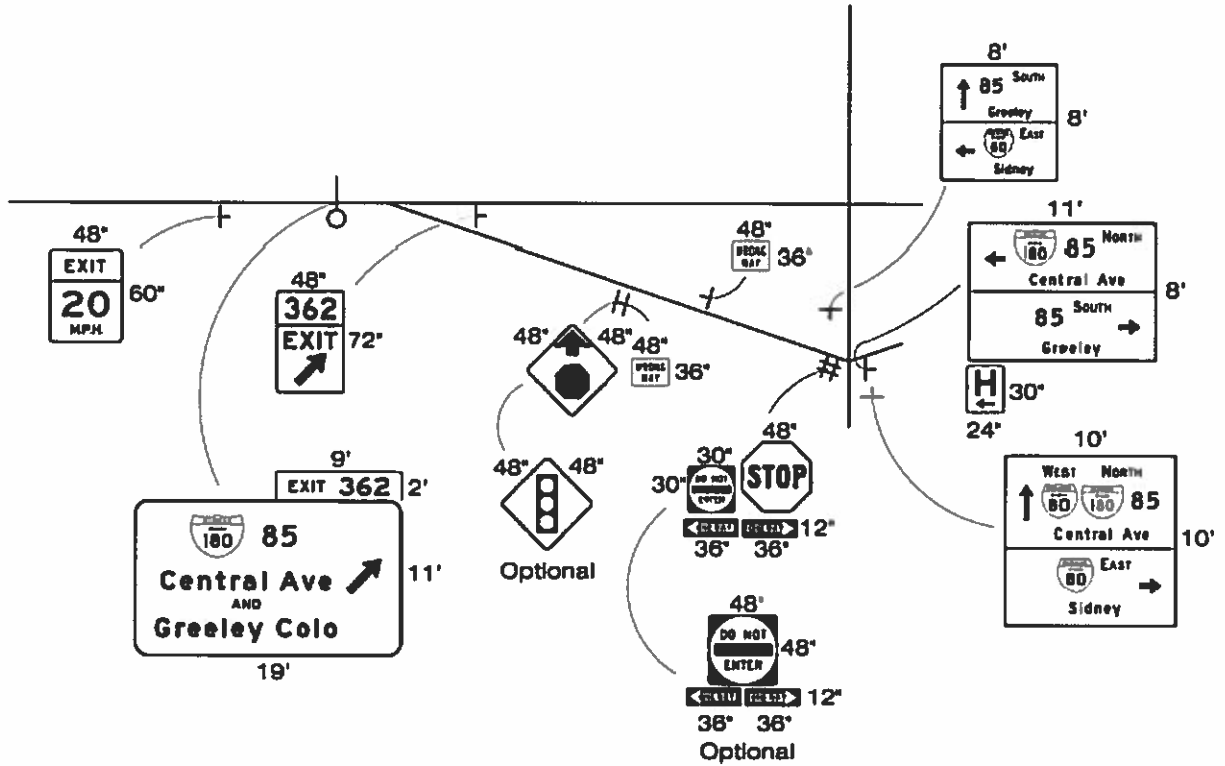

Figure A-7 Interchange Off Ramp NHS Crossroad



A-8 Sequence of Signs

Leaving town on an Interstate Highway the sequence of signs from the last interchange is a follows:

- 1) Route Markers
- 2) Speed Limit
- 3) Distance
- 4) Emergency Parking Only
- 5) 511 Signing (may be omitted at the discretion of the Engineer)

Leaving town on a non-Interstate Highway the sequence of signs is as follows:

- 1) Route Markers
- 2) Speed Limit
- 3) Distance
- 4) 511 Signing (may be omitted at the discretion of the Engineer)

In all cases, repeat the entire sequence every 20 miles.

APPENDIX B – TYPICAL SIGNING NOTES

B-1 Permanent Signing Notes

REQUEST SIGN FABRICATION LAYOUT SHEETS FROM THE WYDOT TRAFFIC PROGRAM FOR ALL PERMANENT HIGHWAY SIGNS.

EACH INSTALLATION IS FIELD CHECKED BEFORE TIMBER BREAKAWAY POSTS ARE ORDERED. POSTS LENGTHS (2 FT INCREMENTS) ARE SUPPLIED BY THE ENGINEER. NO VARIATION IN MOUNTING HEIGHT IS PERMITTED.

EACH INSTALLATION IS FIELD CHECKED BEFORE ROUND TUBULAR STEEL POSTS ARE ORDERED. POST LENGTHS (1 FT INCREMENTS) ARE SUPPLIED BY THE ENGINEER. NO VARIATION IN MOUNTING HEIGHT IS PERMITTED.

EACH INSTALLATION IS FIELD CHECKED BEFORE SQUARE TUBULAR POSTS ARE ORDERED. POST LENGTHS (1 FT INCREMENTS) ARE SUPPLIED BY THE ENGINEER. NO VARIATION IN MOUNTING HEIGHT IS PERMITTED.

RETROREFLECTIVE TYPE IX SHEETING FOR LETTERS AND SYMBOLS, AND RETROREFLECTIVE TYPE IV SHEETING FOR BACKGROUND IS REQUIRED FOR ALL NEW WHITE ON GREEN SIGN PANELS, EXCLUDING REFERENCE MARKER PANELS.

RETROREFLECTIVE TYPE IV SHEETING IS REQUIRED FOR ALL NEW SIGN PANELS NOT INCLUDED IN NOTE XX.

RETROREFLECTIVE TYPE IV SHEETING IS REQUIRED FOR ALL NEW REFERENCE MARKER PANELS.

TYPE IX SHEETING IS REQUIRED FOR THE FLOURESCENT YELLOW PORTION OF SIGN PANELS.

3M SERIES 1179 BROWN SHEETING OR APPROVED EQUAL IS REQUIRED FOR ALL NEW SIGN PANELS REQUIRING BROWN BACKS. SEE HIGHWAY SIGN SUMMARY.

3M SERIES 1170 BLACK SHEETING OR APPROVED EQUAL IS REQUIRED FOR ALL NEW SIGN PANELS CALLING FOR BLACK LEGEND AND BORDER.

FOR SIGN INSTALLATION AND ASSEMBLY, SEE SIGN STRUCTURE SHEETS.

AT LOCATIONS WHERE DRILLED SHAFT FOUNDATIONS ARE TO BE REMOVED, REMOVE THE TOP OF THE FOUNDATION TO A MINIMUM OF 6 INCHES BELOW GRADE OR COMPLETELY REMOVE THE DRILLED SHAFT FOUNDATION. AFTER REMOVAL, FILL HOLE TO EXISTING GRADE. REMOVED DRILLED SHAFT FOUNDATIONS ARE PROPERTY OF THE CONTACTOR.

SHOP DRAWINGS ARE REQUIRED FOR SIGN NUMBER(S) X.

MOUNT NEW SIGN PANELS USING NEW HARDWARE AND ENSURE THAT THE NEW SIGNS ARE MOUNTED AT THE SAME VERTICAL CLEARANCE AS THE EXISTING SIGN PANELS. CENTER NEW OVERHEAD SIGN PANELS OVER APPROPRIATE LANE(S).

FIELD DRILL ALL VERTICAL CLIP ANGLES TO ASSURE PROPER FIT AND VERTICAL CLEARANCE.

CLEARANCE DIMENSIONS ARE SUPPLIED BY THE ENGINEER FOR SIGNS XX AND YY.

UNLESS OTHERWISE SHOWN IN THE SIGN STRUCTURE DETAILS, USE ONLY VERTICAL CLOSURE STRIPS.

AFTER THE REMOVAL OF THE CLEARANCE SIGN AND ALL ASSOCIATED HARDWARE FROM STEEL BRIDGE GIRDERS, INSTALL GALVANIZED HIGH STRENGTH BOLTS, WASHERS, AND LOAD INDICATING WASHERS AND NUTS INTO THE INITIAL INSTALLATION HOLES IN ACCORDANCE WITH SUBSECTION 815.2 OF THE 2010 STANDARD SPECIFICATIONS.

ALL EXISTING SIGNING NOT CONFORMING TO THE STANDARDS OF THESE PLANS IS CONSIDERED NO WORK.

REMOVE AND STOCKPILE ALL CITY AND COUNTY OWNED SIGNS LOCATED WITHIN THE PROJECT LIMITS. STOCKPILE LOCATION WILL BE DETERMINED BY THE ENGINEER. REMOVAL OF CITY AND COUNTY OWNED SIGNS IS INCIDENTAL TO THE CONTRACT PAY ITEM REMOVAL OF SIGNS.

ALL NEW SIGN PANELS ARE STATE FURNISHED. MOUNTING HARDWARE IS FURNISHED BY THE CONTRACTOR. THE SIGNS WILL BE AVAILABLE FOR PICKUP MONTH XX, 20XX AND MAY BE PICKED UP BY THE CONTRACTOR AT THE WYOMING DEPARTMENT OF TRANSPORTATION SIGN SHOP, 5300 BISHOP BLVD., CHEYENNE, WYOMING. CONTACT MR. MIKE CALAWAY OF THE WYDOT SIGN SHOP AT 307-777-4168. LABOR TO LOAD SIGNS IS THE RESPONSIBILITY OF THE CONTRACTOR.

B-2 Sign Summary Notes

XX SIGN INSTALLATIONS TO BE REMOVED, SEE REMOVAL OF SIGNS SUMMARY.

XX SIGN INSTALLATIONS TO BE REMOVED AND RESET, SEE RESET SIGNS SUMMARY.

REFERENCE MARKER PANELS, EA, CONSISTS OF A COMPLETE REFERENCE MARKER PANEL ASSEMBLY PER LOCATION.

FOR REFERENCE MARKER INSTALLATION AND ASSEMBLY, SEE REFERENCE MARKER SHEET.

XX TYPE II AMBER DELINEATORS, PLACED AT ALL APPROACHES.

XX TYPE III CRYSTAL DELINEATORS, PLACED ON SHOULDERS.

PLACED AT MAINTENANCE CROSSOVERS.

DELINEATORS TO BE PLACED AS DIRECTED BY THE ENGINEER.

FOR DELINEATOR PLACEMENT SEE STANDARD PLAN SHEET 702-B1.

REMOVAL OF EXISTING DELINEATORS IS CONSIDERED INCIDENTAL TO THE NEW DELINEATOR PAY ITEMS AND BECOME PROPERTY OF THE CONTRACTOR.

QUANTITY INCLUDES XXX.XX SF OF .125" ALUMINUM FOR NEW SIGN PANELS AND XXX.XX SF OF .040 ALUMINUM OVERLAY.

BID ITEM SIGN POST, SQ TUBULAR STEEL CONSISTS OF

XX – 2" X 2" 12 GA STEEL POSTS
XX – 2 ¼" X 2 ¼" 12 GA STEEL POSTS
XX – 2 ½" X 2 ½" 12 GA STEEL POSTS

XX TYPE I CRYSTAL DELINEATORS, OUTSIDE SHOULDER (MAINLINE).

XX TYPE I AMBER DELINEATORS, INSIDE SHOULDER (MAINLINE).

XX TYPE II CRYSTAL DELINEATORS, OUTSIDE SHOULDER (RAMPS).

XX TYPE II AMBER DELINEATORS, INSIDE SHOULDER (OFF RAMPS).

XX OVERHEAD SIGN LUMINAIRES AND WIRING TO BE REMOVED FROM OVERHEAD SIGN STRUCTURE AT SIGN LOCATION XXX. INCLUDED IS THE REMOVAL OF THE I BEAMS THAT EXTEND BELOW THE SIGN PANELS..

SEE FLEXIBLE DELINEATOR SHEET.

THE REMOVAL OF FLASHING BEACONS AND ELECTRICAL IS CONSIDERED INCIDENTAL TO THE CONTRACT PAY ITEM, REMOVAL OF SIGNS, LUMP SUM.

B-3 Traffic Control Notes

PROVIDE A MAINTAINER, ONSITE, AT ALL TIME (24 HOURS A DAY, 7 DAYS A WEEK) IF TRAFFIC IS BEING DIVERTED OR PROTECTED BY TEMPORARY TRAFFIC CONTROL DEVICES.

XX IMPACT ATTENUATORS ARE REQUIRED.

XX PORTABLE TRAFFIC SIGNAL SYSTEM ARE REQUIRED.

XX PORTABLE VARIABLE MESSAGE SIGNS ARE REQUIRED AND TO BE PLACED AND USED AS DIRECTED BY THE ENGINEER.

LANE RENTAL IS BEING UTILIZED ON THIS PROJECT.

A + B BIDDING IS BEING UTILIZED ON THIS PROJECT.

PROVIDE A MEANS OF ANCHORING THE TEMPORARY CONCRETE BARRIER RAILS TO THE BRIDGE DECK. ENSURE THE ANCHORAGE SYSTEM MEETS THE SPECIFICATIONS AND GUIDELINES OF NCHRP 350 OR THE AASHTO MANUAL FOR ASSESSING SAFETY HARDWARE (MASH). SUBMIT THE PROPOSED ANCHORAGE SYSTEM TO THE ENGINEER A MINIMUM OF 14 CALENDAR DAYS BEFORE THE TEMPORARY BARRIER RAIL INSTALLATION.

A PORTABLE TRAFFIC SIGNAL SYSTEM IS REQUIRED FOR EACH BRIDGE.

FLARE TEMPORARY CONCRETE BARRIER AT A RATE OF 12:1 AWAY FROM THE ACTIVE TRAVELED LANE FOR A MINIMUM OF 15 FEET.

XXX FEET IS ESTIMATED FOR STRUCTURE XXX PER PHASE