

Chapter 1

General Design Information

Section 1.02 – Structure Selection and Geometry

Introduction

This section of the design manual provides guidance on the procedure for selection of the most cost-effective and appropriate structure for a particular bridge site. Information is also provided to help determine structure geometrics such as skew, clearances, lengths, etc.

Structure Selection or Structure Rehabilitation Report

The purpose of the Structure Selection or Structure Rehabilitation Report (SSR / SRR) is to provide enough background information so that reviewers can effectively evaluate the proposed final design and the concepts it is based on. The report should describe the project, the proposed structure, and give reasons why the bridge type, size, and location were selected. The report should concisely summarize the information. A single report is recommended if multiple structures are included in a project.

The intent of these reports is the collection of pertinent data required for the design of the structure, in addition to documentation of design decisions. Pertinent data shall be extracted from other discipline reports and summarized in this report for use by the structure designers.

The SSR / SRR will include the following sections, where applicable. Not all sections will apply to all structures.

Structure Selection Report Outline

General Background

- Project Description
- Right-of-way restrictions
- Permits and restrictions
- Railroad clearances or restrictions
- Design Specifications

Environmental

- Wetlands
- Length of Detour
- Historical sites
- Contaminated areas
- Recreation areas
- Threatened species areas
- Environmental commitments listed in the environmental documentation

Design Concepts Rationale for:

- Building new bridge versus widening existing one
- Use of bridge versus culvert
- Foundations support assumptions
- Seismic load assumptions

Geometry and Layout

- Roadway width
- Traffic volumes
- Profile grade
- Horizontal alignment
- Design exceptions
- Sidewalks
- Railing

Hydraulics

- Waterway opening
- High water elevation
- Clearance
- Bank protection
- Floodway information
- Deck drains

Foundations

- Piling, spread footings, or drilled shafts
- Fills and surcharges
- Settlement
- Lateral earth loads
- Seismic Loads

Structure Selection/Recommendations

- Span length, skew, and span arrangement
- Type of superstructure
 - Girder type and spacing
 - Fixity at abutment & piers
 - Location and type of expansion joints
 - Deck thickness and corrosion protection system
- Type of substructures and location
- Alternate structure types considered and estimated costs
- Stage construction and detour requirements
- Aesthetics
- Maintenance considerations
- Feasibility of construction
- Cost estimate of the proposed work

The following additional items should be considered and addressed as practical in the report:

- Alignment and span configurations of the new bridge in relation to the existing bridge
- Proposed treatment of the runoff and comparison of the number of drains
- Discuss the sizes, numbers, and removal methods of the existing bents, footings and piles within the ordinary high water mark.
- Discuss the sizes, numbers, and construction methods of the new bents, footings and piles within the ordinary high water mark.
- Amount or extent of fill and/or riprap
- Amount of wetland impacted

Structure Rehabilitation Report Outline

General Background

- Project Description
- Summary of Structures including applicable FMIS codes
- Right-of-way restrictions
- Permits and restrictions
- Railroad clearances or restrictions
- Design Specifications
- Identify if structures being rehabilitated are candidates from the Bridge Management System
- Bridge railing type and condition

including exposed curb height
(NCHRP 350 compliant, MASH
compliant or substandard)

- Pedestrian railing type
(compliant with current edition
of AASHTO or substandard)

Structure Summary

- Summary of how bridge
rehabilitation affects Project
Development, Geology,
Materials Program,
Environmental Services
- Summary of bridge rehabilitation

Environmental

- In stream work or anticipated
ground disturbances
- Historical significance
- Lead paint mitigation needed

Structure Rehabilitation

Recommendations

- Summary of deficiency and
proposed work to correct
deficiency
- Appendix of Structure
Information
- Cost estimate of the proposed
work
- Standard structure information
report from database

Bridge lengths shall be in 5'-0" increments unless space constraints require otherwise. Refer to the tables in the Bridge Applications Manual (BAM) Chapter 4.1 - Preliminary for general and structural characteristics of the most common bridge types.

Span lengths and substructure locations should avoid existing substructures and be aligned with the channel or crossroad. It is

recommended to minimize cuts and fills by best fitting the structure to the site geometry. Selection of final structure geometry shall depend on structural requirements, hydraulics, alignment, geology, land use, affect on adjacent property, personal and vehicle safety, and economics. Other factors, such as environment and aesthetics, may need to be considered. Experience and good engineering judgment are the key factors.

Piers (solid shaft columns) or bents (multi-column) shall be placed parallel with the feature intersected and located to minimize interference. The use of bents in streams where heavy scour and large quantities of debris are possible is discouraged.

Desired freeboard from design high water elevation to bottom of lowest girder is 7'-0" where significant drift or ice jams are expected, as listed in the Hydraulic Report. Elsewhere the minimum desired freeboard shall be 3'-0" unless approved by Bridge Program Staff. Desired freeboard for major irrigation ditches is 2'-0". If the above noted freeboard values require a large grade raise or additional girders, the design freeboard will need to be discussed with Bridge Program Staff.

The US Corp of Engineers (USCOE) and the Federal Emergency Management Agency (FEMA) may require different freeboard values than those described above. The Hydraulics Section and the agencies should be consulted when dealing with structures under their jurisdiction.

Structure Grades & Slopes

Bridge grades, including vertical curvature, typically follow the road grades set by the Project Development Section.

Consideration should be given to restrictions on grades required by vertical clearances and the Americans with Disabilities Act (ADA) for sidewalks and bicycle paths. An example of a structure requiring one or more of these restrictions is an urban railroad overpass.

Culvert slopes are based on matching the stream (or approach roadway grades) and should be kept at a minimum of 0.3% to ensure drainage. When culverts are used as pedestrian underpasses, consideration should be given to allowing pedestrians continuous vision through the underpass from one approach to the other.

Structure Widths

The clear bridge roadway width should be as wide as the approach pavement and paved shoulders and is taken from the Road Plans. Minimum roadway widths for highway and bridges are available in the WYDOT Design Guides.

Bridge clear roadway widths for BROS projects shall be based on the BROS Design Guides located at the following:
https://www.dot.state.wy.us/home/engineering_technical_programs/bridge/bros.html

The width of curbs for new structures shall be 1'-8" when TL3BRGRAIL NCHRP 350 or TL4BRGRAIL 350 railing is used and 1'-3 1/2" when TL4BRGRAIL – MASH railing is used. This width includes the 1 1/2" slab extension beyond RF of the curb. Curb widths for rehabilitations should match the existing width, but have a minimum width of 1'-4". The curb width for bridges crossing over railroad tracks is 2'-2" to accommodate future installations of splashboard and safety fence. If texturing on the outside edge of the deck and curb is going to be used, an additional 2" of width will be required for clearance of the rebar to the form liners.

The current standard clear sidewalk width is 5'-0". This is usually measured from the front face of the pedestrian rail to the rear face of the bridge rail base plate or the rear face of the barrier rail.

Consideration of the rubrail connection at the end of the bridge should also be considered when determining clear sidewalk widths.

The recommended minimum clear two-way bicycle path width is 10'-0", while the minimum clear one-way bicycle path width is 5'-0". A bicycle path should be considered to have two-way traffic unless effective measures are taken to ensure one-way traffic.

The total width for the 5'-0" and 10'-0" clear sidewalks are 7'-0" and 12'-0" respectively to accommodate standard bridge and pedestrian railing. Total sidewalk widths need to be adjusted when decorative pedestrian railing is used. Sidewalks on bridges need to meet minimum ADA requirements for width, running slope and cross slope. The maximum cross slope allowed for ADA is 2%. Special attention is needed for bridges that are located within superelevations as these may exceed the maximum cross slope. For further information, see WYDOT ADA Guidelines for Accessibility 2021.

For bridges on a horizontal curve, the following guidelines should be used when determining the structure layout:

A straight deck and girders should be considered when the throw of the curve is less than 15".

When the throw is between 6" and 15", the working line should be placed to split the throw.

When the throw is greater than 15", a curved deck should be used. Straight girders can be used with a curved deck if the cantilever lengths stay within the design standards.

When using a straight deck and girders, the bridge clear roadway width should not be increased without approval of Bridge Program Staff to encompass the entire curved roadway section. The length of the bridge, curvature, or skew may not allow the above noted guidelines to be used. In these cases, the bridge layout should be discussed with Bridge Program Staff.

Structure Skews

Bridge skews shall be in 5 degree increments and limited to 45 degrees maximum, unless required by site or right-of-way constraints, required roadway alignment, and/or required geometry of the feature spanned. Skews greater than 45 degrees need to be approved by the Bridge Program Staff.

Skews for hydraulic culverts shall match stream geometry and be shown in 1 degree increments. Non-hydraulic culvert skews may match the existing terrain or approach roadway, but will usually be normal to the intersected road.

Structure Clearances

The following clearances establish the minimum standards. Additional clearances shall be provided where necessary to meet sight distances, through drainage, and railroad or traveled way requirements at specific locations. Sign structures and pedestrian overpasses have a higher minimum vertical clearance because of their lower vehicle impact resistance.

Clear zones and guardrail requirement are determined by the Project Development Program. Clearance behind the guardrail shall be provided along the face of the obstructions and supports located within the clear zone and shall be in accordance with the Standard Plans. Clearance behind barrier railing shall be as shown in the below diagrams.

Overhead sign structures at locations with curbs and no shoulders shall be located a minimum of 1'-6" beyond the face of the curb where possible. Where a continuous parking lane is provided, no clearance is required but a minimum 2'-0" setback to obstructions is desirable to avoid interference with opening vehicle doors.

The minimum vertical clearances for bridges are as shown in the following details. Pedestrian bridges shall have a minimum clearance 2'-0" greater than the clearance established for major overcrossing structures within the vicinity, but not less than 18'-0".

All new or relocated sign structures shall have a minimum vertical clearance of 19'-0" to the lowest protruding feature (i.e., signs, signals, luminaires, etc.). Existing sign structures may maintain a minimum clearance of 18'-0" to the lowest protruding feature.

For pedestrian and bicycle path underpass clearances, refer to the AASHTO Guide for the Development of Bicycle Facilities, with all revisions to date.

The clearance from retaining walls to the guardrail shall be at least the minimum noted in the AASHTO LRFD Bridge Design Specification.

The following details show minimum horizontal and vertical clearances for various bridge structures. The vertical clearance for bridges over a road should be measured from the highest crossroad point, including the travel lanes and shoulders.

Interstate Highway Underpass

The substructures and toe of sloping paving or face of retaining walls shall be placed outside the clear zone. On Interstate 80 horizontal clearances shall accommodate a future lane in both directions.

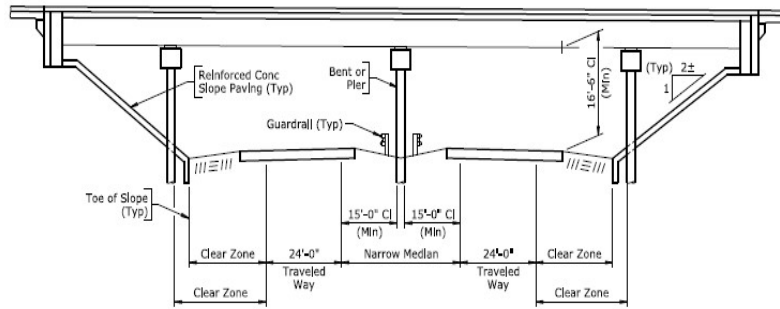

INTERSTATE HIGHWAY UNDERPASS
 Narrow Median - 60'-0" or less

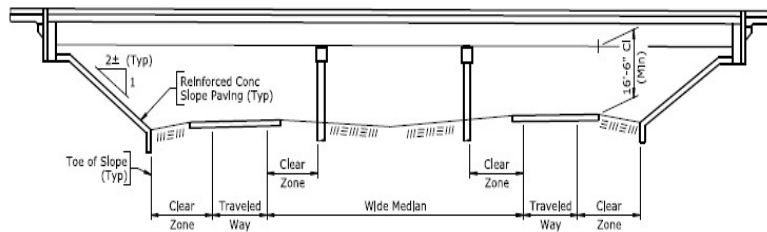

INTERSTATE HIGHWAY UNDERPASS
 Wide Median - Over 60'-0"

NHS, Non – NHS, and Local Interchange

The substructures and toe of sloping paving or face of retaining walls shall be placed outside the clear zone. If this requires a grade raise on mainline, roadway guardrail may be used to reduce bridge lengths as approved by Bridge Program Staff. A 42” high single slope concrete barrier is typically required to shield columns and piers unless they are designed to resist vehicular collision force. See Vehicular Collision Force, Section 1.03-Loads and Load Factors for additional information. The following diagram shows minimum offsets that are required when using 42” high concrete barrier rail. When using other roadway guardrail types, the offsets shown in WYDOT Standard Plans shall be used.

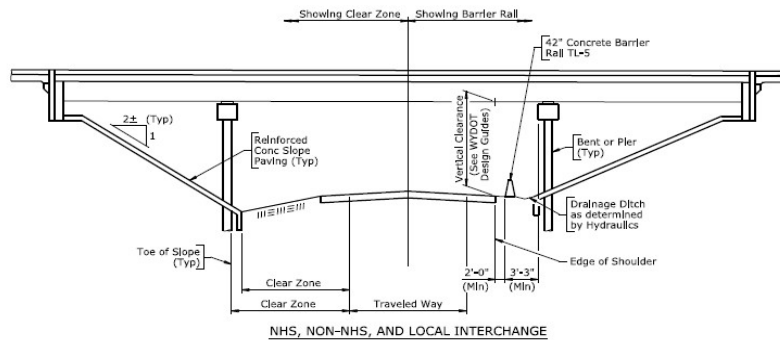

Machinery Pass Separation:

The substructures and toe of sloping paving or face of retaining walls shall be placed to facilitate 14' minimum opening. (14'-6" preferred). The minimum width shall accommodate the anticipated use of the cross road or minimum requirements shown below, whichever is greater. This should be verified through District Offices.

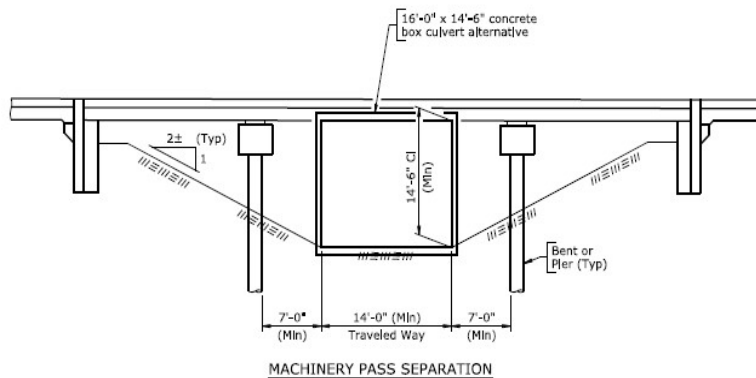

Railroad Separation

The horizontal and vertical clearances shall be in accordance with the latest addition of the Union Pacific Railroad – BNSF Railway Guidelines for Railroad Grade Separation Projects. The specific railroad company should be contacted prior to Structure Selection Report to determine requirements for future track and access road locations. A formal design deviation is required to place substructures within existing railroad right of way. This shall be submitted with the Conceptual Bridge Layout for Geology, RR, & Vertical Grade.