



# WYOMING'S TRANSPORTATION SYSTEM

Supporting the economy and connecting our communities.

STATE TRANSPORTATION IMPROVEMENT PROGRAM 2024-2029

[Ralph Tarango](#)

[Ralph.Tarango@wyo.gov](mailto:Ralph.Tarango@wyo.gov)

307-745-2100



# People of WYDOT



**Ralph Tarango**  
District Engineer



**Brandt Lyman**  
Transportation Commissioner  
(Albany, Carbon & Sweetwater Counties)

## District 1

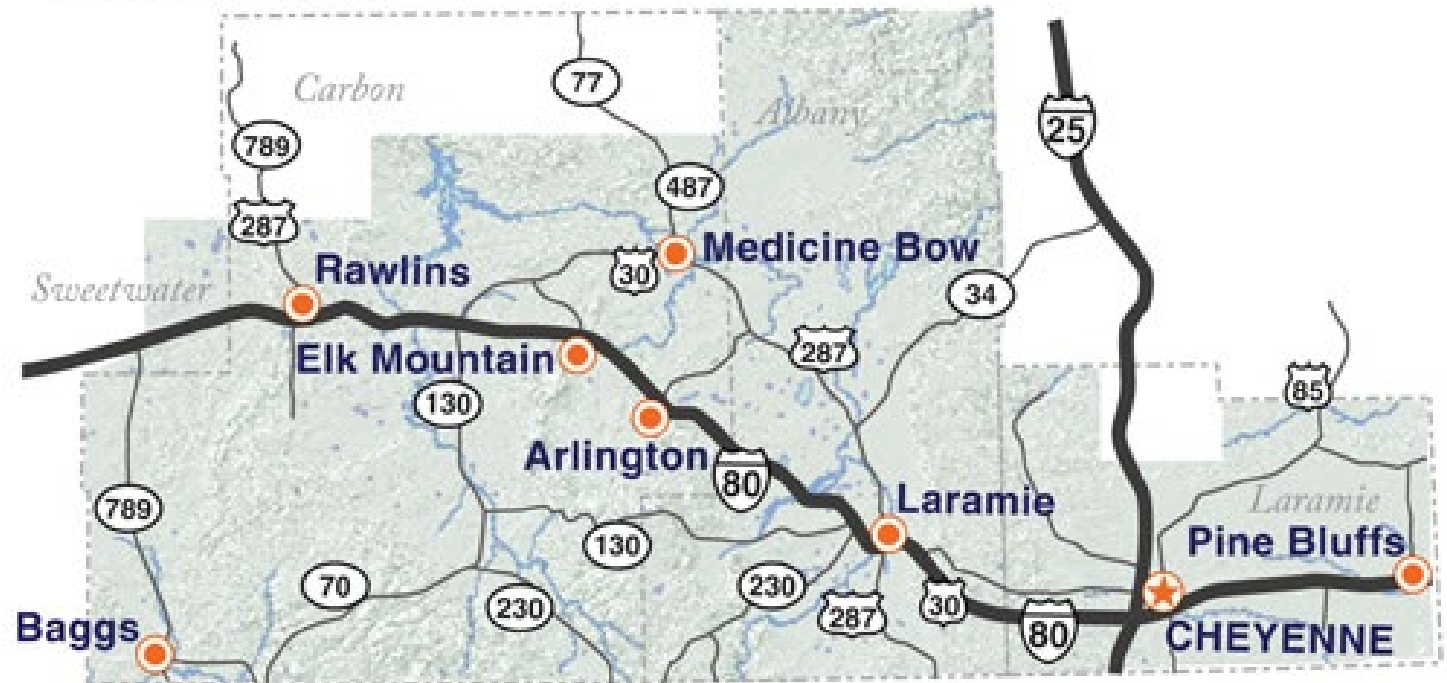



# People of WYDOT

**Darin Westby**  
Director



**Taylor Rossetti**  
Deputy  
Director



**Mark Gillett**  
Chief  
Engineer



**Tom DeHoff**  
Assistant  
Chief  
Engineer -  
Operations



**Keith Fulton**  
Assistant  
Chief Engineer  
– Engineering  
and Planning



**John Davis**  
Management  
Services  
Manager –  
Grant  
information





# People of WYDOT

**Tim Morton**  
District  
Maintenance  
Engineer



**Ryan Shields**  
District  
Construction  
Engineer



**Tyler  
Chapman**  
Interim  
Commander  
of Troops J,  
P, H

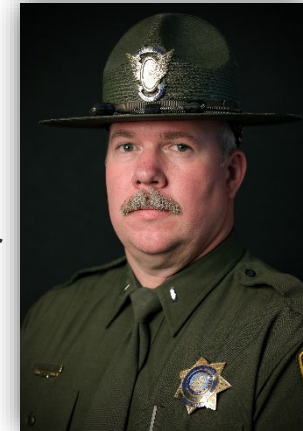

**Roy  
Sommers**  
District  
Equipment  
Supervisor



**Taylor  
McCort**  
District Traffic  
Engineer

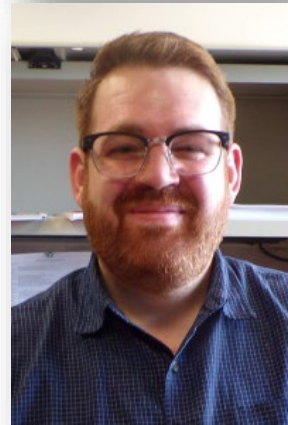

**Andrea  
Staley**  
Public  
Relations  
Specialist





# People of WYDOT

## Construction



**Steve Cook**  
Resident  
Engineer



**Kory Cramer**  
Resident  
Engineer

## Maintenance



**Eric Anderson**  
Area Maintenance Supervisor



**Rich Barber**  
Foreman



**Al Branscom**  
Foreman



# Purpose, Mission, Vision & Values

**Purpose:** Support Wyoming's economy while safely connecting communities and improving the quality of life.

**Mission:** Provide a safe and effective transportation system.

**Vision:** Excellence in Transportation

**Values:** Respect, Integrity, Dedication, Excellence, Safety (RIDES)

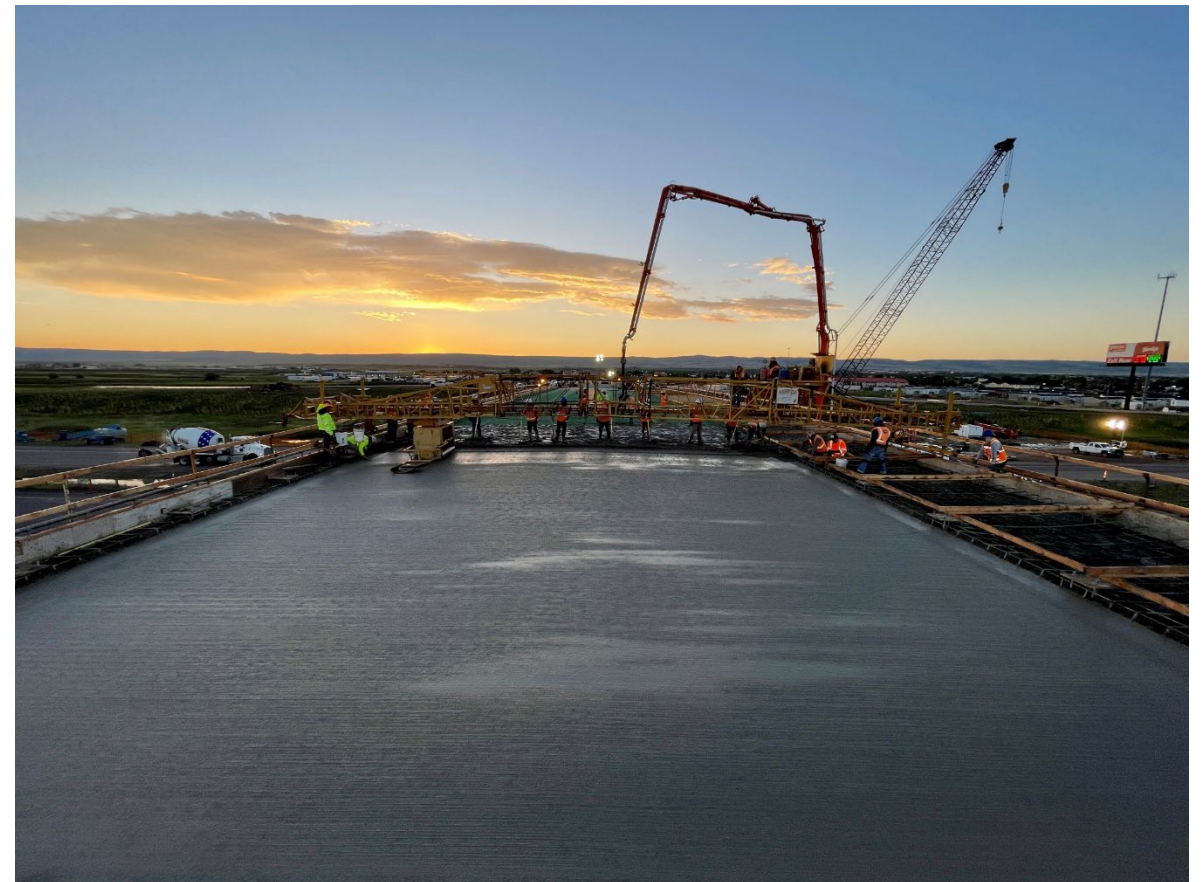



# WYDOT Areas of Focus and Strategic Objectives

## WYDOT Areas of Focus

Recognize/Retain/Recruit

Secure Additional Funding

Develop the Brand

## WYDOT Strategic Objectives

- Serve Our Customer
- Ensure Transparency and Public Engagement
- Value Our Team
- Develop and Maintain Strategic Partnerships
- Appropriately Manage Resources
- Continue to Improve and Innovate





# Guiding Principles

1. Align expenditures with available revenue amount and source
2. Focus on addressing identified critical life safety issues.
3. Prioritize WYDOT asset preservation based on condition of the asset to meet established goals (as appropriate)
4. Improve operational effectiveness and efficiency
5. Prioritize activities to minimize negative impacts to the public
6. Address mobility and capacity through system improvements and enhancements





# Developing the Brand

All WYDOT employees are responsible for developing our brand by building relationships, creating positive experiences, and strengthening partnerships.

WYDOT's mission takes employees all across the state and agency operations have the ability to impact every citizen within Wyoming every day.



# Divisions and Programs

- Emergency Communications
- Highway Patrol
- Aeronautics
- Driver Services

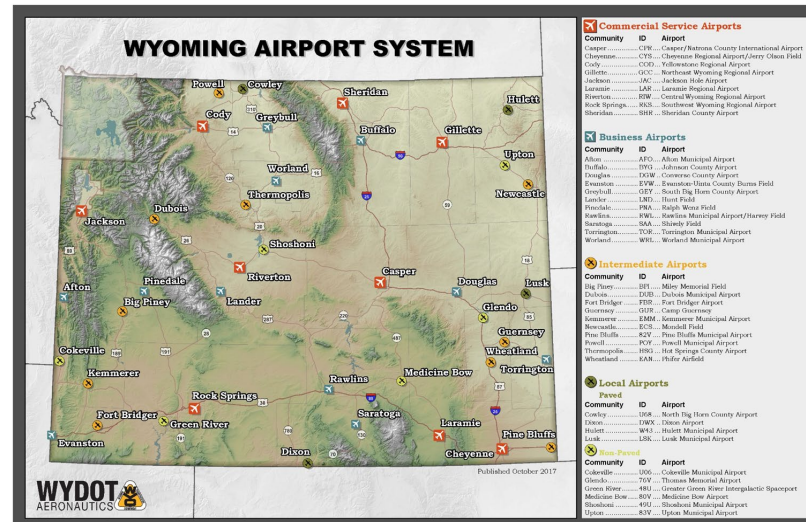



# Maintenance

Tim Morton, District Maintenance Engineer

**Responsible for keeping infrastructure operational and safe**

- Snow removal
- Pavement maintenance
- Fencing
- Vegetation control
- Disaster relief
- Rest Areas
- Permits
- Facilities
- ...and so much more

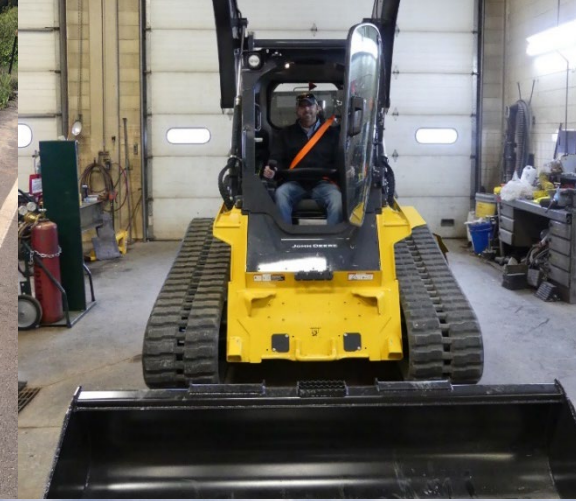



# Traffic

Taylor McCort, District Traffic Engineer

## Responsible for the maintenance and operation of all traffic safety devices

- Crews stripe 3240 travel miles
- Traffic Signals - 100
- Signs – 13,000
- Crosswalks - 370
- Access Permits – 44 for FY23, 39 for FY24
- Safety and Traffic Studies
- High Mast Towers
- Development Reviews - 250 Per Year





# Equipment

## District Equipment Supervisor

Keep fleet in working order by managing over 800 items:

- 80 Plow truck units
- 25 loaders
- WHP Fleet
- Rotaries
- Paver
- Mowers and more
- Manage State fuel sites

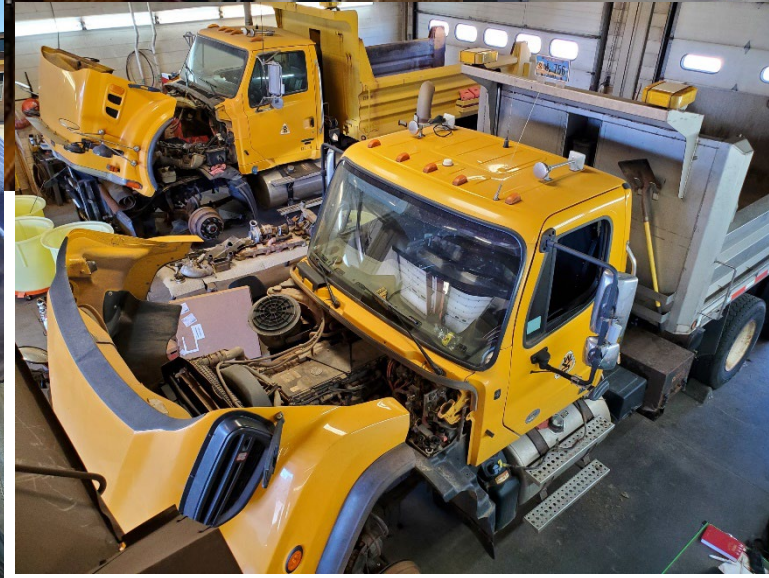



# Public Involvement

Andrea Staley, Sr. Public Relations Specialist

Educate and inform the public of WYDOT activities in the community

- Outreach
- Public Meetings
- Construction Project Updates
- Winter Weather Messaging
- Media Release
- Highway Safety Messaging
- Recruiting
- Address public concerns

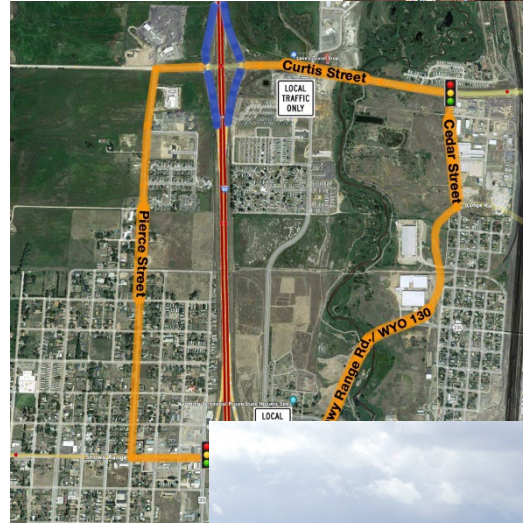



# Construction

## Ryan Shields, District Construction Engineer

### Oversees and Manages Highway Construction Projects

- Manages Contracts totaling ~\$60 Million per Year
- 6 Resident Engineer Offices
  - (Rawlins, Laramie, Cheyenne)
- Construction Engineers, Surveyors, and Technicians
- Finals Office
- Survey Support

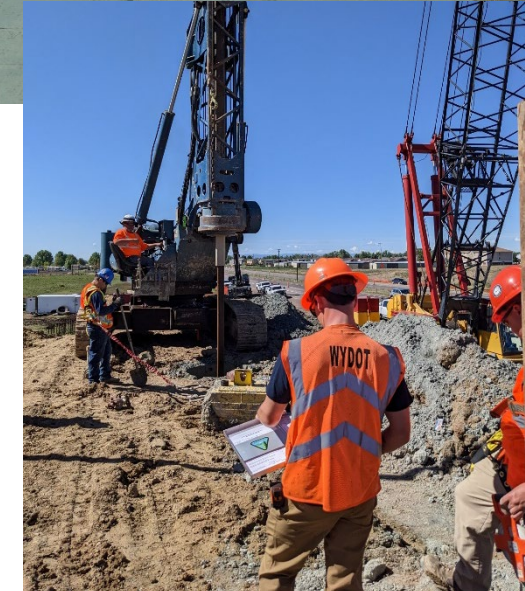
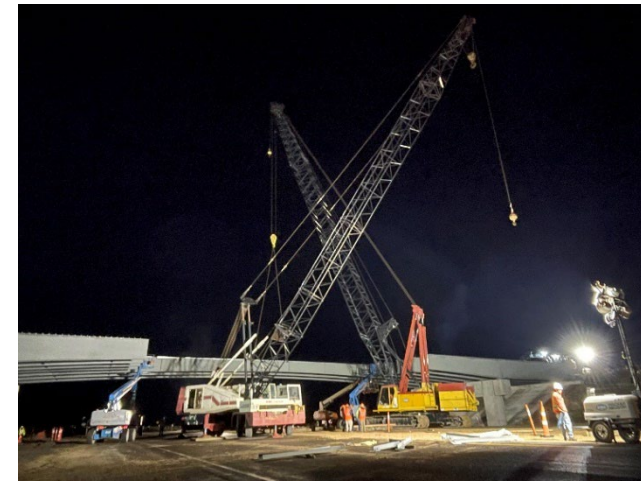



# WYDOT Overview

- Highways ~6,700 Miles of Roads and 2000 Bridges Statewide

Highway miles in District 1	
Interstate	247
US Highways	209
State Highways	403
Frontage/Other	272
<b>Total (miles)</b>	<b>1131</b>
Bridges in District 1	
On-system	367
Off-system	139
<b>Total (bridges)</b>	<b>506</b>

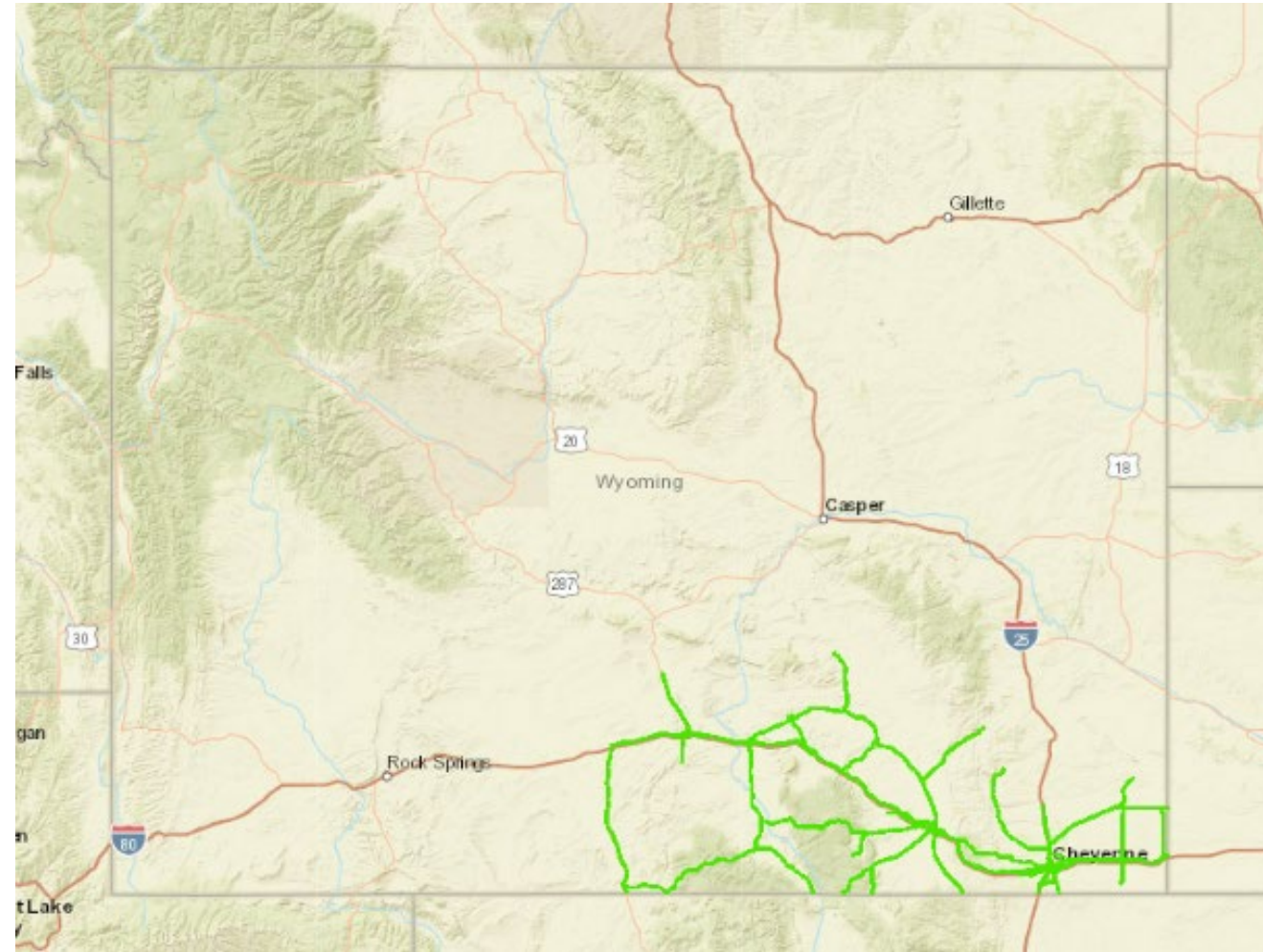

Wyoming Transportation Fact Book -

[https://www.dot.state.wy.us/home/administration/strategic\\_performance/fact\\_book.html](https://www.dot.state.wy.us/home/administration/strategic_performance/fact_book.html)





# District 1 – Projects by Type (2024-2030)

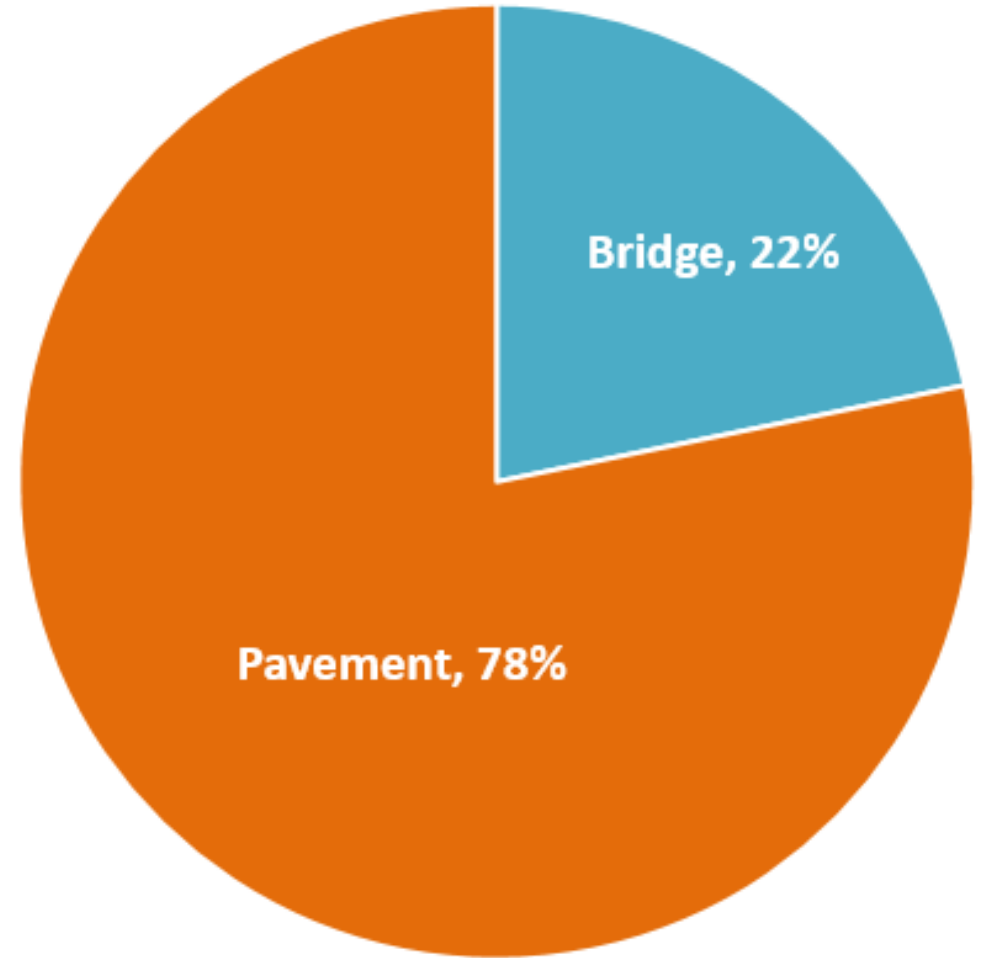
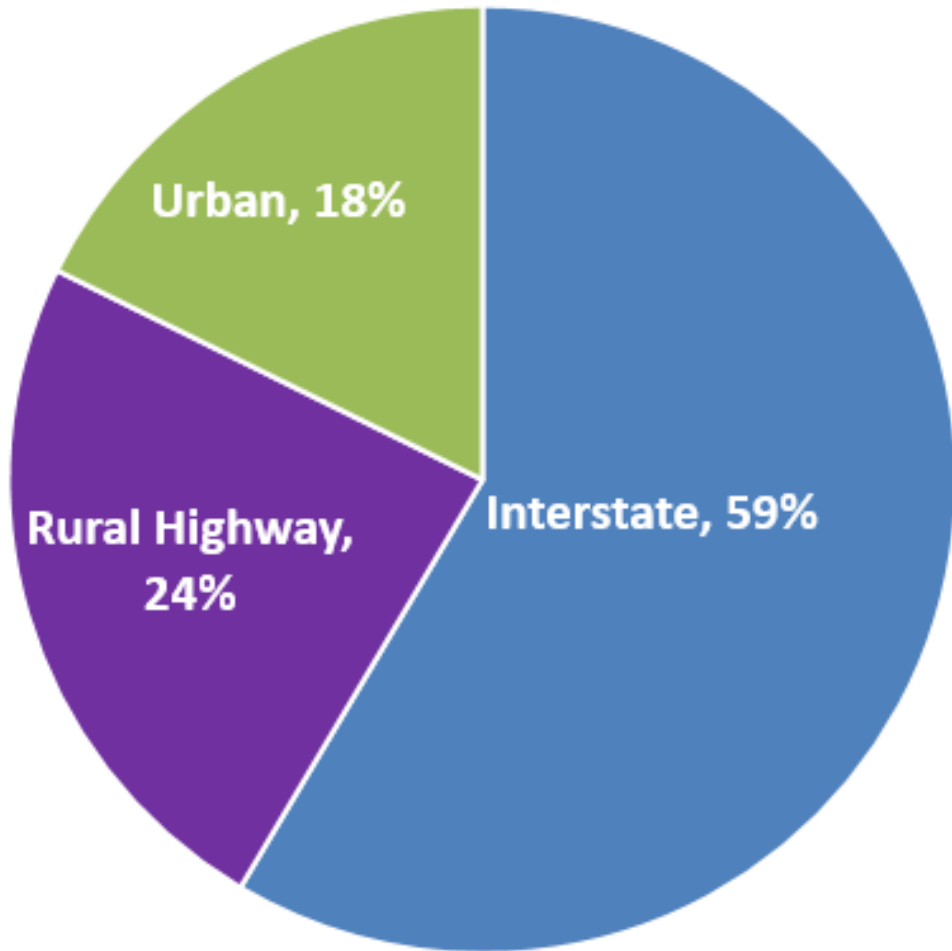



# Safety Projects

In addition to typical highway and bridge projects, WYDOT programs dedicated safety projects to address high crash areas or “hot spots.” Examples in District 1 include:

- Enhanced Pavement Markings
- High Friction Wearing Surfaces
- Intersection Improvements





# Infrastructure Investment & Jobs Act (IIJA)

**FY 2025 Surface Transportation Funding**

**\$362,470,085 – Statewide**

**\$58,758,874 – District 1**

*\*Construction dollars only (does not include bridges or EV)*

*\*Generally, \$100+M in new funding each year (Statewide)*

## **State vs Federal Funding**

**National Average – 70% State / 30% Federal**

**Wyoming – 27% State / 73% Federal**



# Bridge Formula Program (BFP)

- 2022 Infrastructure Investment and Jobs Act (Bipartisan Infrastructure Law) dedicated funding for bridges
  - Replace or rehabilitate bridges in poor condition
  - \$45 million/year for 5 years (\$225 million)
  - Minimum 15% (\$6.75 million/year) to off-system bridges.  
100% federal funds on qualifying bridges
- Planned to address 44 bridges in poor condition
- **Seeing large increase in unit bridge costs**
  - **Average has gone from \$175/sf to \$400/SF**
  - **Will continue to fund the off-system bridges currently in the program**



# Challenges and Risks

- Inflation Outpacing Funding
- Aging System & Assets
- Personnel Shortages
- Growth outpacing Funding

**Cost to Pave One Mile of Interstate**

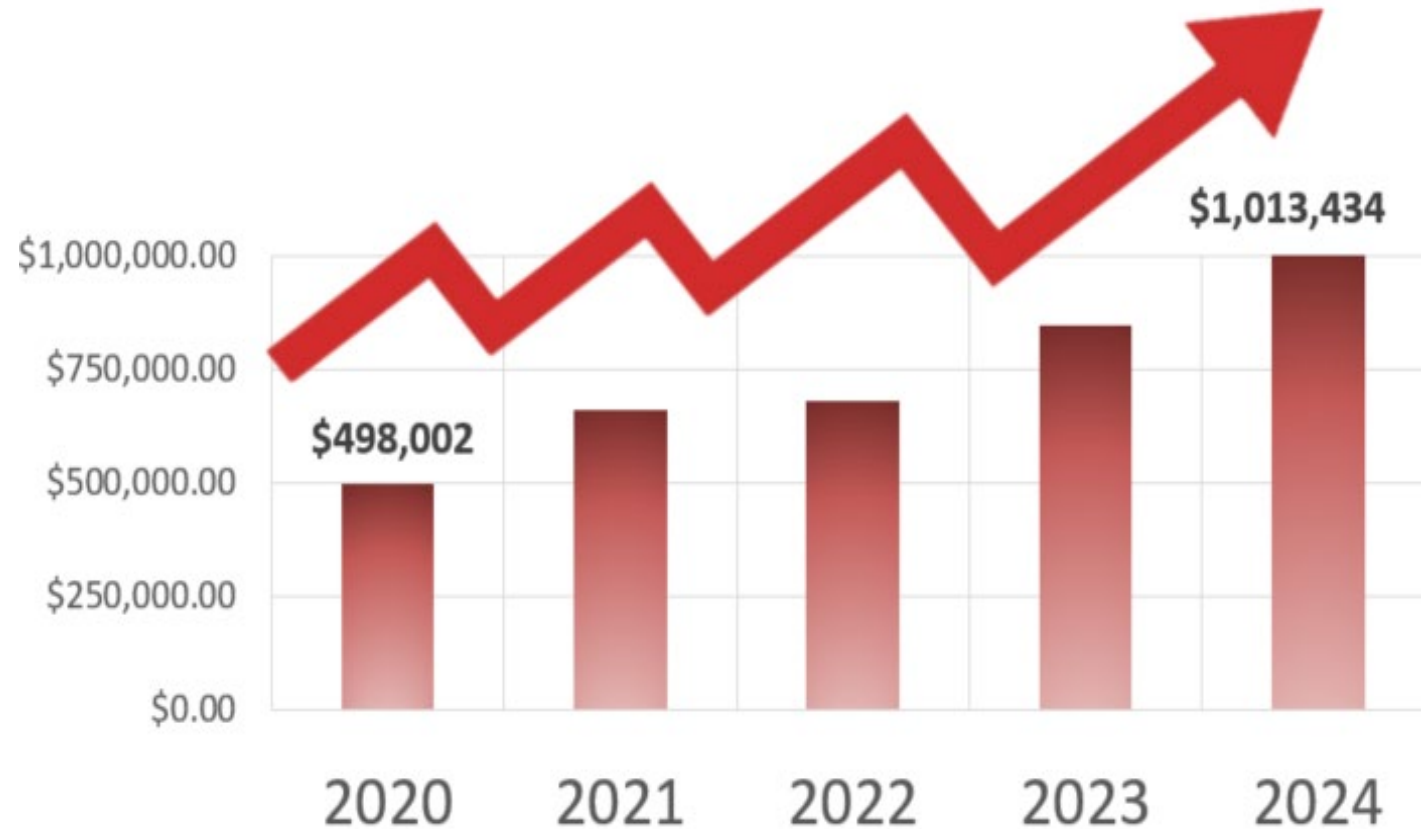



# Strategies and Innovative Solutions

- Statewide Asset Management Systems
- Efficient Pavement and Bridge Designs
- Value Engineering Process
- Innovative Contracting Methods (Lane Rental, A+B, Incentive/Disincentive)

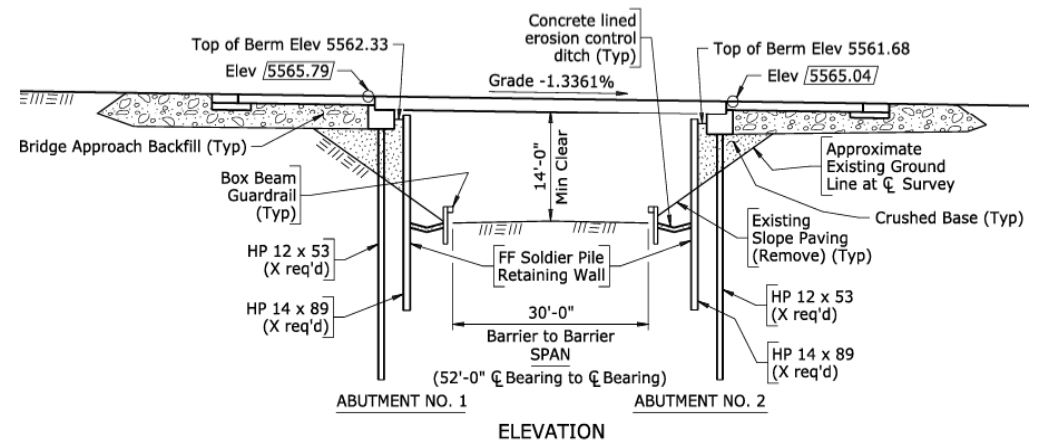



# Partnering with Communities

- Local Project Funding and Participation
  - Context Sensitive Amenities (CSA)
  - Enhancement Funds
- Grant Opportunities (TAP, Transit, HRRR...)
- Off-System Bridge Funding
  
- **Relationships are Everything!**





# Local Grant Opportunities

## Local Governments

→ **Contact WYDOT to learn about opportunities for:**

- Construction partnerships
- Supply purchases

→ **Local Government Grants**

- Transit
- TAP
- HRRR
- CMAQ
- CRIP

**Sara B.  
Janes Ellis**  
Local  
Government  
Coordinator  
307-777-4438







# Other Grant Opportunities



**WYDOT web page – Transportation Grant opportunities**  
([https://www.dot.state.wy.us/home/business\\_with\\_wydot/grants.html](https://www.dot.state.wy.us/home/business_with_wydot/grants.html))



**Contains information on grants that can be applied for by local governments**

- Competitive federal grants
  - Includes guidance documentation
- Zero emission vehicles
- Highway safety behavioral
- Aeronautics
- Local government transportation programs



**Links to additional resources and guidebook on the new infrastructure law.**



# Local Grants Awarded

Year	Funding Type	Award Amount	Project Description
FY2024	N/A		
FY 2023	HRRR	\$22,700	Albany Co. Delineators
FY 2022	TAP	\$500,000	Laramie Spring Creek Trail
FY 2021	<ul style="list-style-type: none"><li>• Transit</li><li>• Transit</li></ul>	<ul style="list-style-type: none"><li>• \$952,200</li><li>• \$74,900</li></ul>	<ul style="list-style-type: none"><li>• University of Wyoming</li><li>• Eppson Center for Seniors, Inc.</li></ul>
FY 2020	N/A		

\*Total TAP, SMAQ, HRRR, Transit funding in Albany Co. from FY 20-FY24 is \$1,549,800



# District 1 STIP 2023-2029

Ryan Shields, District Construction Engineer



# STIP Process Overview

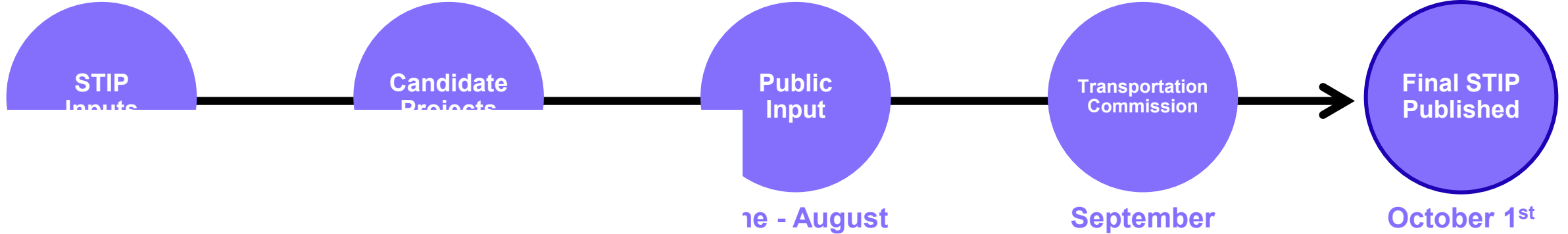

- 
- 
- 
- 
- 
- 
- 
- 
- 
- 

- Other Projects

- Transportation Commission
- Maritime Commission
- Commission
- Transportation Alternative
- am (TAP)
- ns
- Agencies
- portation Agencies
- s
- Governments
- al Agencies
- Bureau of Indian Affairs
- Local Governments

- Approves STIP
- Federal Highway Administration (FHWA) concurs in approval
- Federal Transit Authority concurs in approval



# STIP Public Engagement

## We Ensure Transparency and Public Engagement in the STIP By:

- Gathering public comment and information to develop the STIP
- Engaging with local, state and federal partners to develop the STIP
- Consistently updating the STIP and posting changes to the website
- Ensuring the STIP Map is available for the public to view and directly submit public comment

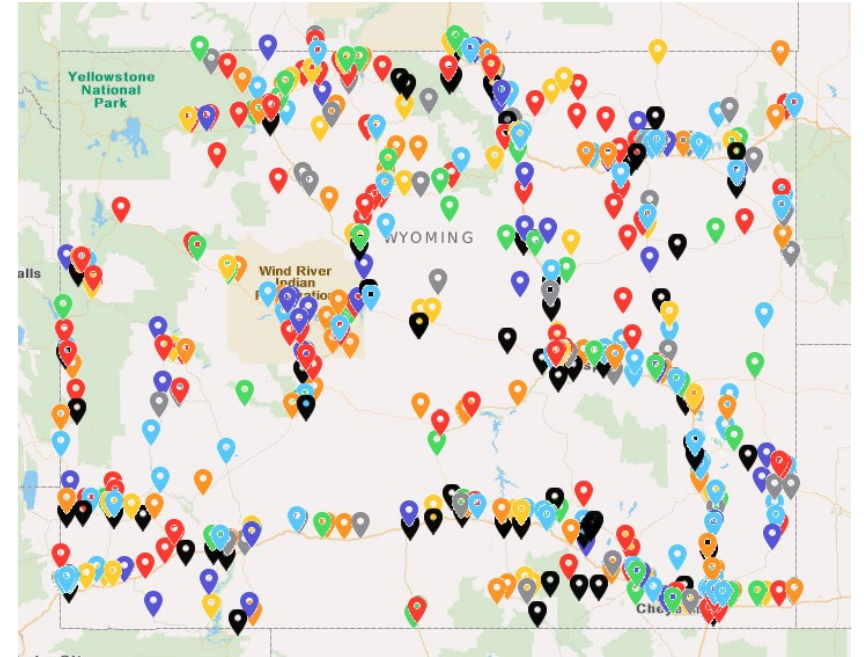

To view or add a comment,  
go to:

<https://webapp.dot.state.wy.us/ao/f?p=951:1:14757550149257:::>



# STIP - What is in the document?



Wyoming Department of Transportation  
5300 Bishop Blvd  
Cheyenne, WY 82009

## STATE TRANSPORTATION IMPROVEMENT PROJECTS COUNTY TOTAL

County		Transportation Projects	Transit Projects	Aeronautics Projects	Total
Albany	2024	\$2,478,000	\$4,316,000	\$6,842,000	\$13,636,000
	2025	\$27,500,000	\$0	\$0	\$27,500,000
	2026	\$12,152,000	\$0	\$4,046,000	\$16,198,000
	2027	\$29,470,000	\$0	\$4,737,000	\$34,207,000
	2028	\$9,930,000	\$0	\$0	\$9,930,000
	2029	\$23,979,000	\$0	\$0	\$23,979,000
	Future Year	\$22,279,000	\$0	\$0	\$22,279,000
	<b>Total</b>	<b>\$127,788,000</b>	<b>\$4,316,000</b>	<b>\$15,625,000</b>	<b>\$147,729,000</b>



# 2024 Construction Projects – Albany County

## 2024 STIP Projects:

---

**\$2.5  
Million**

- **Curtis Street Overlay and Bridge Work**





# 2025 Construction Projects – Albany County

## 2025 STIP Projects:

**\$27.5  
Million**



Wyoming's Transportation System

- 3<sup>rd</sup> Street – Overlay, ADA, Spring Creek Structure
- **Bill Nye Ave. Phase II (USAC Project)**



- **Left Turn Lanes (Safety Project)**
  - **US 287 & Rawhide Rd.**
  - **WY 130 at Laramie Regional Airport**





# 2026 Construction Projects – Albany County

## 2026 STIP Projects:

---

**\$12.2  
Million**

- US 287 South 5-Lane
- Grand Avenue 30<sup>th</sup> to I-80
- US 30 Bridge Replacement





# 2027 Construction Projects – Albany County

## 2027 STIP Projects:

**\$29.5  
Million**

- I-80 Bridge Replacements – Blair
- Bridge Repair – US 287 UPRR Viaduct
- I-80 WBL Laramie West - Overlay





# 2028 Construction Projects – Albany County

## 2028 STIP Projects:

---

**\$9.9  
Million**

- I-80 EBL, Laramie West – Overlay
- I-80 Telephone Canyon Overlay





# 2029 Construction Projects – Albany County

## 2029 STIP Projects:

---

**\$26.1  
Million**

- I-80 Grand Avenue Section – Overlay
- I-80 Bridge Rehab – Grand Ave Interchange
- I-80 Bridge Replacement – Dutton Creek Road





# 2030 Construction Projects – Albany County

## 2030 STIP Projects:

---

**\$22.4  
Million**

- WY 130 – Overlay (RM 10 to 17)
- WY 13 – Bridge Replacement & Rehab
- Bridge Replacement – US 287 South & UPRR





# Wind Development in Southeast WY

**WYDOT works with wind energy companies on road use agreements, especially when areas see major traffic changes from the development.**

**WYDOT will do our best to help companies with their development while also considering road maintenance and the safety of the traveling public.**





## Visit on-line STIP page



## Provide feedback

- On current and upcoming projects
- What are we missing - Safety, mobility, congestion, etc.
- What would you like to see in the STIP document?
- What is the best way to present information?

**WYDOT is hosting a online web page to provide information on the Statewide Transportation Improvement Program (STIP)**

See meeting schedules and presentations

Use the Interactive map to see projects and provide comments

The online meeting can be accessed at  
<https://www.dot.state.wy.us/STIP>



# Open Floor Discussion

- What WYDOT routes or areas do you have concern with, or hear from your constituents about?
- How can WYDOT improve our public outreach?
- Other discussion?





# WYOMING'S TRANSPORTATION SYSTEM

Supporting the economy and connecting our communities.

STATE TRANSPORTATION IMPROVEMENT PROGRAM 2023-2029

To access today's presentation, visit <https://www.dot.state.wy.us/STIP>